

## Series CD04 - inch



AVENTICS™ Series CD04 - inch











## 3/2-directional valve, Series CD04

- 3/2
- Qn = 900 l/min
- Pilot valve width : 26 mm
- NC NO
- Pipe connection
- Compressed air connection output : 1/8-27 PTF
- Electrical connection : Plug, EN 175301-803, form B, 3-pin
- Manual override : with detent
- With spring return
- Pilot : Internal



|                                  |                                   |
|----------------------------------|-----------------------------------|
| Version                          | Spool valve, positive overlapping |
| Activation                       | Electrically                      |
| Pilot                            | Internal                          |
| Sealing principle                | Soft sealing                      |
| Working pressure min./max.       | 3 ... 10 bar                      |
| Control pressure min./max.       | 3 ... 10 bar                      |
| Ambient temperature min./max.    | -15 ... 50 °C                     |
| Medium temperature min./max.     | -15 ... 50 °C                     |
| Medium                           | Compressed air                    |
| Max. particle size               | 50 µm                             |
| Oil content of compressed air    | 0 ... 1 mg/m <sup>3</sup>         |
| Nominal flow Qn                  | 900 l/min                         |
| Nominal flow 1 ► 2               | 900 l/min                         |
| Nominal flow 2 ► 3               | 900 l/min                         |
| Compressed air connection        | according to ANSI B1.20.3         |
| Connector standard               | EN 175301-803:2006                |
| Protection class with connection | IP65                              |
| Compatibility index              | 14                                |
| Duty cycle                       | 100 %                             |
| Weight                           | See table below                   |

## Technical data

| Part No.   |   | MO  |       | Compressed air connection |            |
|------------|---|---|-------|---------------------------|------------|
|            |   |   |       |                           | Input      |
| R412012695 |  |  | NC NO |                           | 1/8-27 PTF |
| R412012696 |  |  | NC NO |                           | 1/8-27 PTF |
| R412012698 |  |  | NC NO |                           | 1/8-27 PTF |
| R412012700 |  |  | NC NO |                           | 1/8-27 PTF |

| Part No.   | Compressed air connection |            |
|------------|---------------------------|------------|
|            | Output                    | Exhaust    |
| R412012695 | 1/8-27 PTF                | 1/8-27 PTF |
| R412012696 | 1/8-27 PTF                | 1/8-27 PTF |
| R412012698 | 1/8-27 PTF                | 1/8-27 PTF |
| R412012700 | 1/8-27 PTF                | 1/8-27 PTF |

| Part No.   | Compressed air connection |               | Operational voltage |          |
|------------|---------------------------|---------------|---------------------|----------|
|            |                           | Pilot Exhaust | DC                  | AC 50 Hz |
| R412012695 | M5                        |               | 12 V                | -        |
| R412012696 | M5                        |               | 24 V                | -        |
| R412012698 | M5                        |               | -                   | 110 V    |
| R412012700 | M5                        |               | -                   | -        |

| Part No.   | Operational voltage | Voltage tolerance |             |             |
|------------|---------------------|-------------------|-------------|-------------|
|            |                     | DC                | AC 50 Hz    | AC 60 Hz    |
| R412012695 | -                   | -10% / +10%       | -           | -           |
| R412012696 | -                   | -10% / +10%       | -           | -           |
| R412012698 | 110 V               | -                 | -20% / +10% | -10% / +20% |
| R412012700 | -                   | -                 | -           | -           |

| Part No.   | Power consumption |          | Holding power |          | Switch-on power |
|------------|-------------------|----------|---------------|----------|-----------------|
|            | DC                | AC 50 Hz | AC 50 Hz      | AC 60 Hz | AC 50 Hz        |
| R412012695 | 4.6 W             | -        | -             | -        | -               |
| R412012696 | 4.8 W             | -        | -             | -        | -               |
| R412012698 | -                 | 8.3 VA   | 7.2 VA        | 7.2 VA   | 10.8 VA         |
| R412012700 | -                 | -        | -             | -        | -               |

| Part No.   | Switch-on power |          | Typ. switch-on time | Typ. switch-off time |
|------------|-----------------|----------|---------------------|----------------------|
|            |                 | AC 60 Hz |                     |                      |
| R412012695 | -               | -        | 13 ms               | 27 ms                |
| R412012696 | -               | -        | 13 ms               | 27 ms                |
| R412012698 | 9.5 VA          | -        | 13 ms               | 27 ms                |
| R412012700 | -               | -        | -                   | -                    |

| Part No.   | basic valve with electrical connector | Weight  |
|------------|---------------------------------------|---------|
| R412012695 | -                                     | 0.32 kg |
| R412012696 | -                                     | 0.32 kg |
| R412012698 | -                                     | 0.32 kg |
| R412012700 | Basic valve without coil              | 0.26 kg |

Nominal flow Qn at 6 bar and  $\Delta p = 1$  bar, MO = Manual override

## Technical information

The min. control pressure must be adhered to, since otherwise faulty switching and valve failure may result!

The pressure dew point must be at least 15 °C under ambient and medium temperature and may not exceed 3 °C .

The oil content of compressed air must remain constant during the life cycle.

Use only the approved oils from AVENTICS. Further information can be found in the "Technical information" document (available in the MediaCentre).

option valve: The input and output compressed air connections can be exchanged.

The valve can thereby be used in the NC or NO operating mode.

## Technical information

| Material |  |
|----------|--|
| Housing  | Die cast zinc Polyamide fiber-glass reinforced |
| Seals    | Acrylonitrile butadiene rubber                 |

## Dimensions

### Dimensions in inches

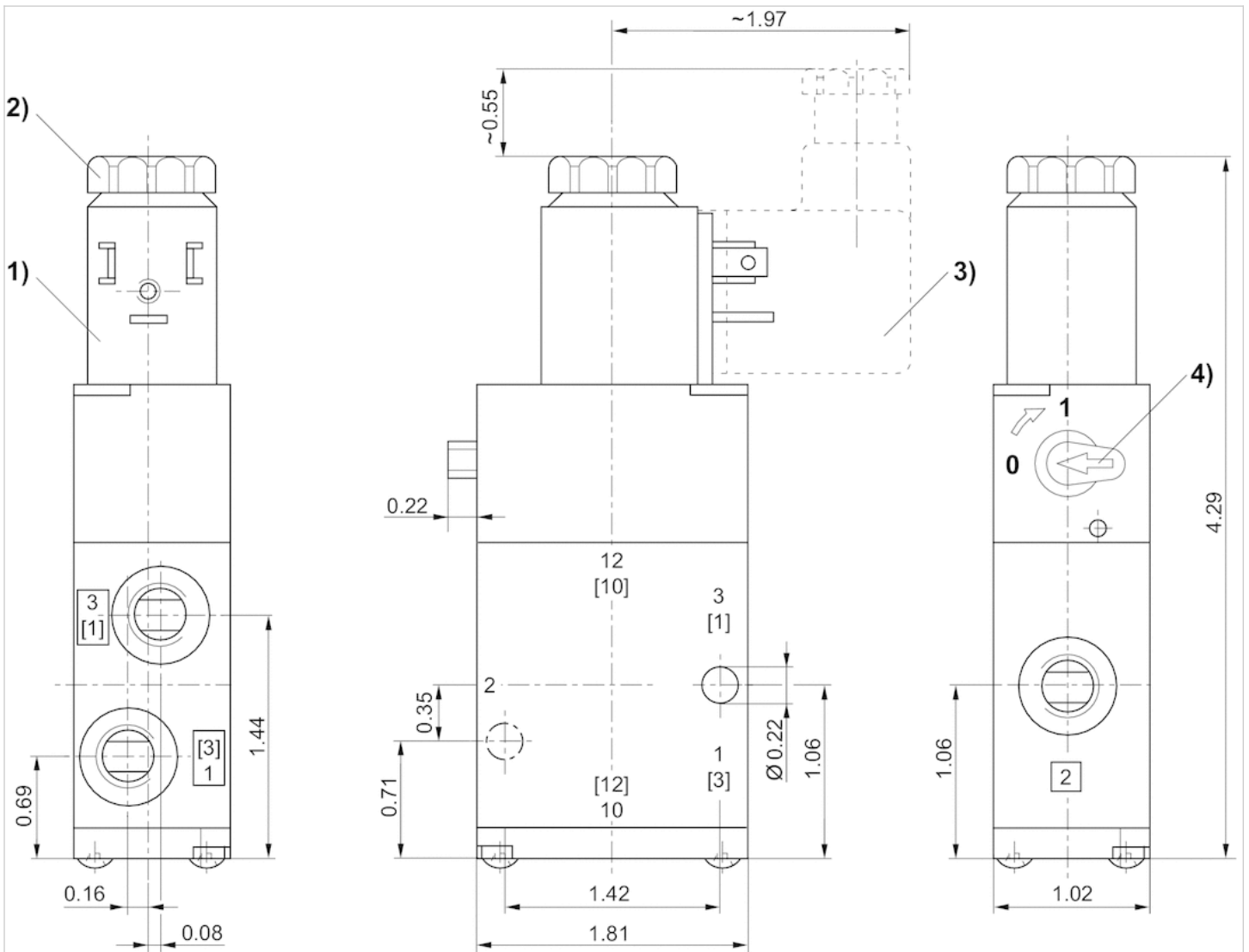

1) Coil can be rotated at 90° intervals 2) After removal of cap M5 internal thread 3) Valve plug connector can be plugged at 180° intervals 4) Manual override

















## 5/2-directional valve, Series CD04

- 5/2
- Qn = 900 l/min
- Pilot valve width : 26 mm
- Pipe connection
- Compressed air connection output : 1/8-27 PTF
- Electrical connection : Plug, EN 175301-803, form B, 3-pin
- Manual override : with detent
- single solenoid
- Pilot : Internal



|                                  |                                   |
|----------------------------------|-----------------------------------|
| Version                          | Spool valve, positive overlapping |
| Activation                       | Electrically                      |
| Pilot                            | Internal                          |
| Sealing principle                | Soft sealing                      |
| Working pressure min./max.       | 3 ... 10 bar                      |
| Control pressure min./max.       | 3 ... 10 bar                      |
| Ambient temperature min./max.    | -15 ... 50 °C                     |
| Medium temperature min./max.     | -15 ... 50 °C                     |
| Medium                           | Compressed air                    |
| Max. particle size               | 50 µm                             |
| Oil content of compressed air    | 0 ... 1 mg/m <sup>3</sup>         |
| Nominal flow Qn                  | 900 l/min                         |
| Nominal flow 1 ► 2               | 900 l/min                         |
| Nominal flow 2 ► 3               | 900 l/min                         |
| Compressed air connection        | according to ANSI B1.20.3         |
| Connector standard               | EN 175301-803:2006                |
| Protection class with connection | IP65                              |
| Compatibility index              | 14                                |
| Duty cycle                       | 100 %                             |
| Typ. switch-on time              | 12 ms                             |
| Typ. switch-off time             | 21 ms                             |
| Mounting on manifold strip       | P-strip                           |
| Weight                           | See table below                   |

## Technical data

| Part No.   |   | MO  | Compressed air connection |            |
|------------|---|---|---------------------------|------------|
|            |   |   | Input                     | Output     |
| R412012840 |  |  | 1/8-27 PTF                | 1/8-27 PTF |
| R412012841 |  |  | 1/8-27 PTF                | 1/8-27 PTF |
| R412012842 |  |  | 1/8-27 PTF                | 1/8-27 PTF |
| R412012843 |  |  | 1/8-27 PTF                | 1/8-27 PTF |
| R412012708 |  |  | 1/8-27 PTF                | 1/8-27 PTF |
| R412012709 |  |  | 1/8-27 PTF                | 1/8-27 PTF |
| R412012711 |  |  | 1/8-27 PTF                | 1/8-27 PTF |
| R412012713 |  |  | 1/8-27 PTF                | 1/8-27 PTF |

| Part No.   | Compressed air connection |               |
|------------|---------------------------|---------------|
|            | Exhaust                   | Pilot Exhaust |
| R412012840 | 1/8-27 PTF                | M5            |
| R412012841 | 1/8-27 PTF                | M5            |
| R412012842 | 1/8-27 PTF                | M5            |
| R412012843 | 1/8-27 PTF                | M5            |
| R412012708 | 1/8-27 PTF                | M5            |
| R412012709 | 1/8-27 PTF                | M5            |
| R412012711 | 1/8-27 PTF                | M5            |
| R412012713 | 1/8-27 PTF                | M5            |

| Part No.   | Operational voltage |          | Operational voltage |
|------------|---------------------|----------|---------------------|
|            | DC                  | AC 50 Hz | AC 60 Hz            |
| R412012840 | 12 V                | -        | -                   |
| R412012841 | 24 V                | -        | -                   |
| R412012842 | -                   | 110 V    | 110 V               |
| R412012843 | -                   | -        | -                   |
| R412012708 | 12 V                | -        | -                   |
| R412012709 | 24 V                | -        | -                   |
| R412012711 | -                   | 110 V    | 110 V               |
| R412012713 | -                   | -        | -                   |

| Part No.   | Voltage tolerance |             |             | Power consumption |
|------------|-------------------|-------------|-------------|-------------------|
|            | DC                | AC 50 Hz    | AC 60 Hz    | DC                |
| R412012840 | -10% / +10%       | -           | -           | 4.6 W             |
| R412012841 | -10% / +10%       | -           | -           | 4.8 W             |
| R412012842 | -                 | -20% / +10% | -10% / +20% | -                 |
| R412012843 | -                 | -           | -           | -                 |
| R412012708 | -10% / +10%       | -           | -           | 4.6 W             |
| R412012709 | -10% / +10%       | -           | -           | 4.8 W             |
| R412012711 | -                 | -20% / +10% | -10% / +20% | -                 |
| R412012713 | -                 | -           | -           | -                 |

| Part No.   | Holding power |          | Switch-on power |          |
|------------|---------------|----------|-----------------|----------|
|            | AC 50 Hz      | AC 60 Hz | AC 50 Hz        | AC 60 Hz |
| R412012840 | -             | -        | -               | -        |
| R412012841 | -             | -        | -               | -        |

| Part No.   | Holding power | Holding power | Switch-on power | Switch-on power |
|------------|---------------|---------------|-----------------|-----------------|
|            | AC 50 Hz      | AC 60 Hz      | AC 50 Hz        | AC 60 Hz        |
| R412012842 | 8.3 VA        | 7.2 VA        | 10.8 VA         | 9.5 VA          |
| R412012843 | -             | -             | -               | -               |
| R412012708 | -             | -             | -               | -               |
| R412012709 | -             | -             | -               | -               |
| R412012711 | 8.3 VA        | 7.2 VA        | 10.8 VA         | 9.5 VA          |
| R412012713 | -             | -             | -               | -               |

| Part No.   | basic valve with electrical connector | Weight  |
|------------|---------------------------------------|---------|
| R412012840 | -                                     | 0.38 kg |
| R412012841 | -                                     | 0.38 kg |
| R412012842 | -                                     | 0.38 kg |
| R412012843 | Basic valve without coil              | 0.33 kg |
| R412012708 | -                                     | 0.38 kg |
| R412012709 | -                                     | 0.38 kg |
| R412012711 | -                                     | 0.38 kg |
| R412012713 | Basic valve without coil              | 0.33 kg |

Nominal flow Qn at 6 bar and  $\Delta p = 1$  bar, MO = Manual override

## Technical information

The min. control pressure must be adhered to, since otherwise faulty switching and valve failure may result!

The pressure dew point must be at least 15 °C under ambient and medium temperature and may not exceed 3 °C .

The oil content of compressed air must remain constant during the life cycle.

Use only the approved oils from AVENTICS. Further information can be found in the "Technical information" document (available in the MediaCentre).

## Technical information

| Material |  |
|----------|--|
| Housing  | Die cast zinc Polyamide fiber-glass reinforced |
| Seals    | Acrylonitrile butadiene rubber                 |



## Dimensions

### Dimensions in inches

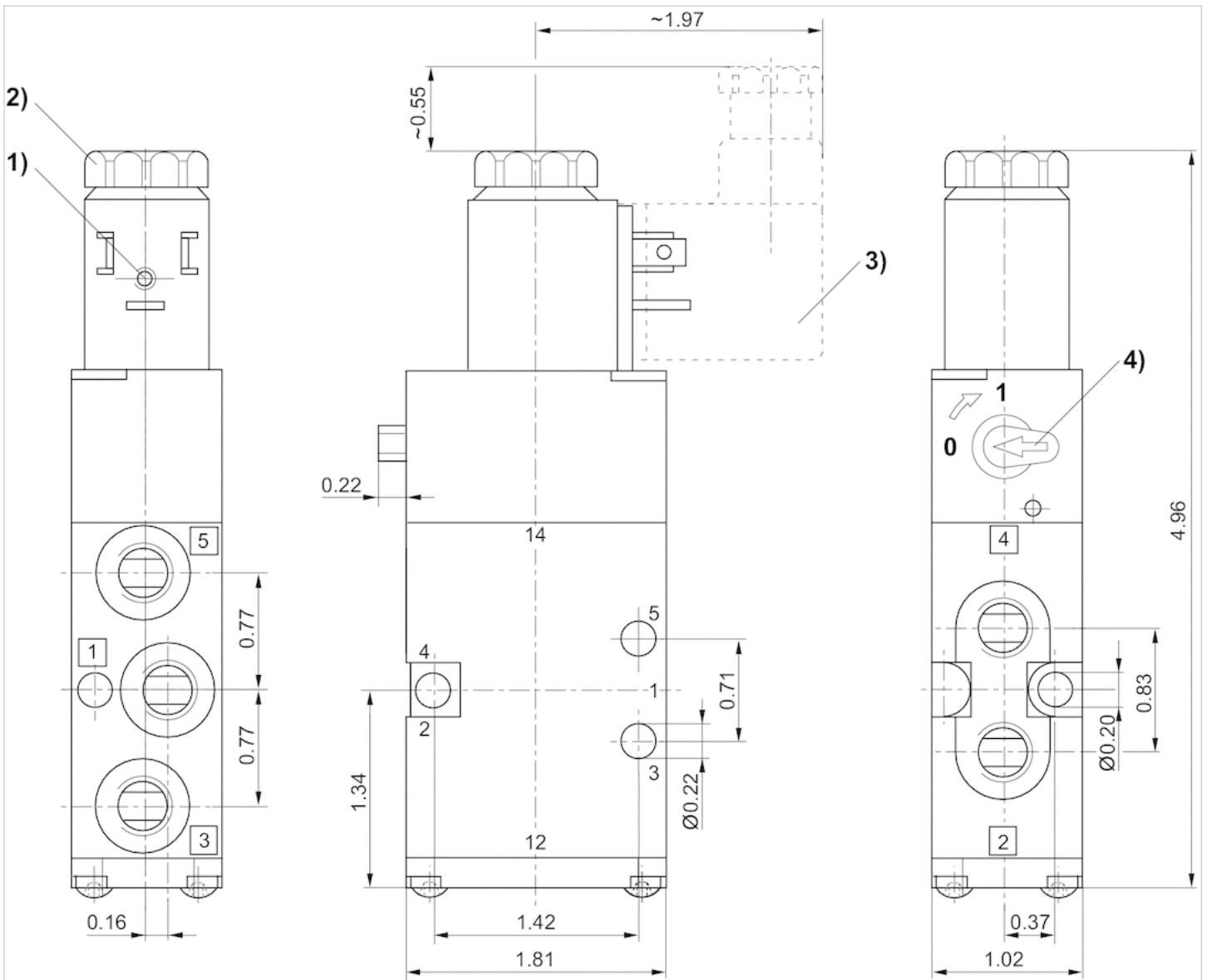

1) Coil can be rotated at 90° intervals 2) After removal of cap M5 internal thread 3) Valve plug connector can be plugged at 180° intervals 4) Manual override







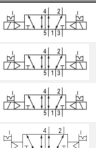
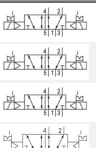

## 5/2-directional valve, Series CD04

- 5/2
- $Q_n = 900$  l/min
- Pilot valve width : 26 mm
- Pipe connection
- Compressed air connection output : 1/8-27 PTF
- Electrical connection : Plug, EN 175301-803, form B, 3-pin
- Manual override : with detent
- double solenoid
- Pilot : Internal

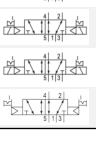

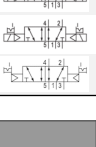
|                                  |                                   |
|----------------------------------|-----------------------------------|
| Version                          | Spool valve, positive overlapping |
| Activation                       | Electrically                      |
| Pilot                            | Internal                          |
| Sealing principle                | Soft sealing                      |
| Working pressure min./max.       | 2 ... 10 bar                      |
| Control pressure min./max.       | 2 ... 10 bar                      |
| Ambient temperature min./max.    | -15 ... 50 °C                     |
| Medium temperature min./max.     | -15 ... 50 °C                     |
| Medium                           | Compressed air                    |
| Max. particle size               | 50 µm                             |
| Oil content of compressed air    | 0 ... 1 mg/m <sup>3</sup>         |
| Nominal flow $Q_n$               | 900 l/min                         |
| Nominal flow 1 ► 2               | 900 l/min                         |
| Nominal flow 2 ► 3               | 900 l/min                         |
| Compressed air connection        | according to ANSI B1.20.3         |
| Connector standard               | EN 175301-803:2006                |
| Protection class with connection | IP65                              |
| Compatibility index              | 14                                |
| Duty cycle                       | 100 %                             |
| Typ. switch-on time              | 12 ms                             |
| Typ. switch-off time             | 12 ms                             |
| Mounting on manifold strip       | P-strip                           |
| Weight                           | See table below                   |

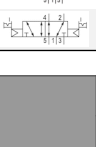
## Technical data

| Part No.   |  | MO  | Compressed air connection |            |
|------------|---|---|---------------------------|------------|
|            |   |   | Input                     | Output     |
| R412012999 |  |  | 1/8-27 PTF                | 1/8-27 PTF |
| R412013000 |  |  | 1/8-27 PTF                | 1/8-27 PTF |
| R412013001 |  |  | 1/8-27 PTF                | 1/8-27 PTF |
| R412013002 |  |  | 1/8-27 PTF                | 1/8-27 PTF |

| Part No.   | Compressed air connection |               |
|------------|---------------------------|---------------|
|            | Exhaust                   | Pilot Exhaust |
| R412012999 | 1/8-27 PTF                | M5            |
| R412013000 | 1/8-27 PTF                | M5            |
| R412013001 | 1/8-27 PTF                | M5            |
| R412013002 | 1/8-27 PTF                | M5            |

| Part No.   | Operational voltage |          | Operational voltage |
|------------|---------------------|----------|---------------------|
|            | DC                  | AC 50 Hz | AC 60 Hz            |
| R412012999 | 12 V                | -        | -                   |
| R412013000 | 24 V                | -        | -                   |
| R412013001 | -                   | 110 V    | 110 V               |
| R412013002 | -                   | -        | -                   |

| Part No.   | Voltage tolerance | Voltage tolerance | Voltage tolerance | Power consumption |
|------------|-------------------|-------------------|-------------------|-------------------|
|            | DC                | AC 50 Hz          | AC 60 Hz          | DC                |
| R412012999 | -10% / +10%       | -                 | -                 | 4.6 W             |
| R412013000 | -10% / +10%       | -                 | -                 | 4.8 W             |
| R412013001 | -                 | -20% / +10%       | -10% / +20%       | -                 |
| R412013002 | -                 | -                 | -                 | -                 |

| Part No.   | Holding power |          | Switch-on power |          |
|------------|---------------|----------|-----------------|----------|
|            | AC 50 Hz      | AC 60 Hz | AC 50 Hz        | AC 60 Hz |
| R412012999 | -             | -        | -               | -        |
| R412013000 | -             | -        | -               | -        |
| R412013001 | 8.3 VA        | 7.2 VA   | 10.8 VA         | 9.5 VA   |
| R412013002 | -             | -        | -               | -        |

| Part No.   | basic valve with electrical connector | Weight  |
|------------|---------------------------------------|---------|
| R412012999 | -                                     | 0.46 kg |
| R412013000 | -                                     | 0.46 kg |
| R412013001 | -                                     | 0.46 kg |
| R412013002 | Basic valve without coil              | 0.36 kg |

Nominal flow Q<sub>n</sub> at 6 bar and Δp = 1 bar, MO = Manual override

## Technical information

The min. control pressure must be adhered to, since otherwise faulty switching and valve failure may result!

The pressure dew point must be at least 15 °C under ambient and medium temperature and may not exceed 3 °C .

The oil content of compressed air must remain constant during the life cycle.

Use only the approved oils from AVENTICS. Further information can be found in the "Technical information" document (available in the MediaCentre).

## Technical information

| Material |  |
|----------|--|
| Housing  | Die cast zinc Polyamide fiber-glass reinforced |
| Seals    | Acrylonitrile butadiene rubber                 |

# Dimensions

## Dimensions in inches

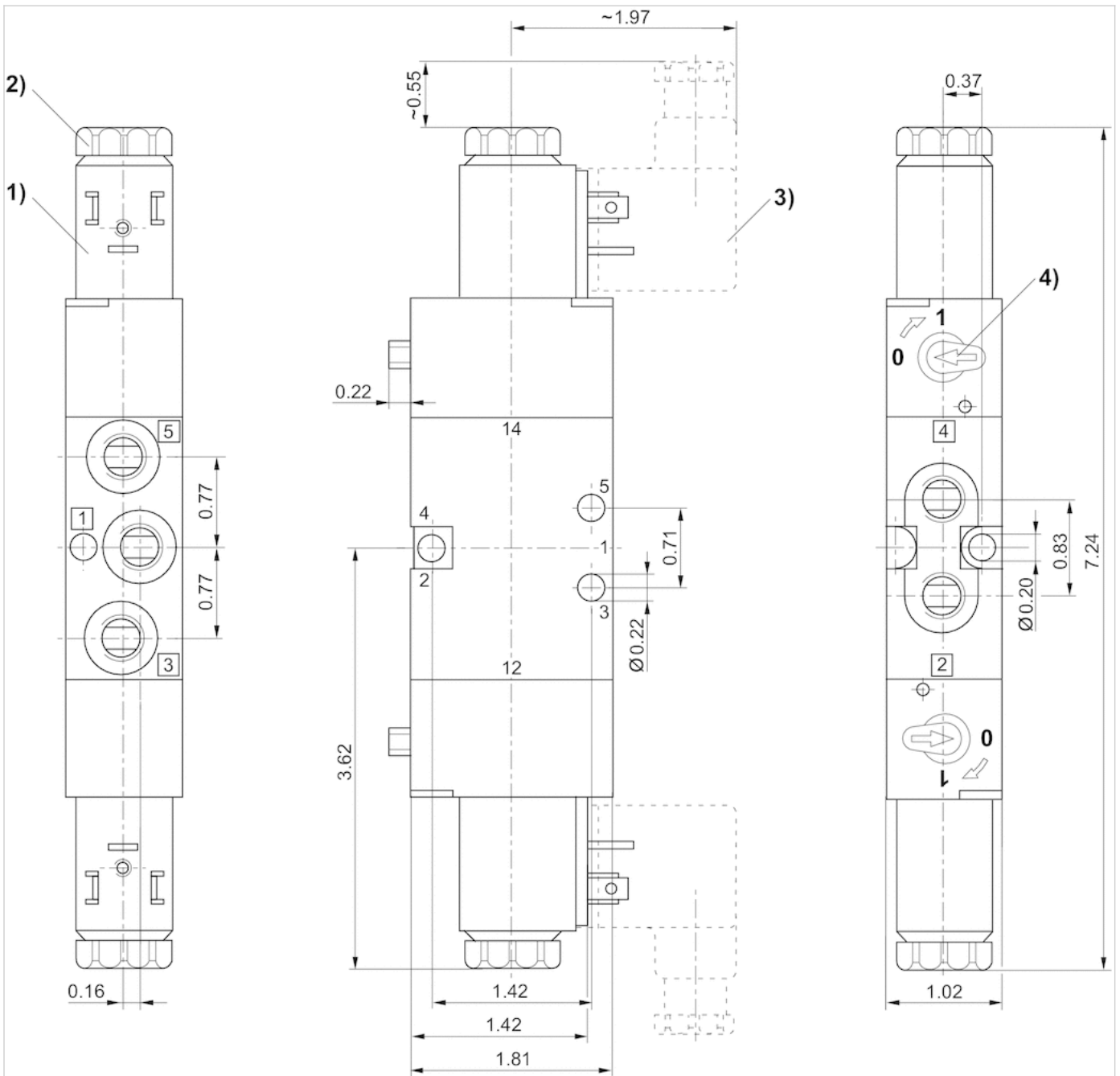

1) Coil can be rotated at 90° intervals 2) After removal of cap M5 internal thread 3) Valve plug connector can be plugged at 180° intervals 4) Manual override













## 5/3-directional valve, Series CD04

- 5/3
- $Q_n = 900$  l/min
- Pilot valve width : 26 mm
- Pipe connection
- Compressed air connection output : 1/8-27 PTF
- Electrical connection : Plug, EN 175301-803, form B, 3-pin
- Manual override : with detent
- With spring return
- Pilot : Internal



|                                  |                                   |
|----------------------------------|-----------------------------------|
| Version                          | Spool valve, positive overlapping |
| Activation                       | Electrically                      |
| Pilot                            | Internal                          |
| Sealing principle                | Soft sealing                      |
| Working pressure min./max.       | 3.5 ... 10 bar                    |
| Control pressure min./max.       | 3.5 ... 10 bar                    |
| Ambient temperature min./max.    | -15 ... 50 °C                     |
| Medium temperature min./max.     | -15 ... 50 °C                     |
| Medium                           | Compressed air                    |
| Max. particle size               | 50 µm                             |
| Oil content of compressed air    | 0 ... 1 mg/m <sup>3</sup>         |
| Nominal flow $Q_n$               | 900 l/min                         |
| Nominal flow 1 ► 2               | 900 l/min                         |
| Nominal flow 2 ► 3               | 900 l/min                         |
| Compressed air connection        | according to ANSI B1.20.3         |
| Connector standard               | EN 175301-803:2006                |
| Protection class with connection | IP65                              |
| Compatibility index              | 14                                |
| Duty cycle                       | 100 %                             |
| Typ. switch-on time              | 12 ms                             |
| Typ. switch-off time             | 27 ms                             |
| Mounting on manifold strip       | P-strip                           |
| Weight                           | See table below                   |

## Technical data

| Part No.   | MO  | Compressed air connection |            |
|------------|---|---------------------------|------------|
|            |   | Input                     | Output     |
| R412013018 |  | 1/8-27 PTF                | 1/8-27 PTF |
| R412013019 |  | 1/8-27 PTF                | 1/8-27 PTF |
| R412013020 |  | 1/8-27 PTF                | 1/8-27 PTF |
| R412012852 |  | 1/8-27 PTF                | 1/8-27 PTF |
| R412013015 |  | 1/8-27 PTF                | 1/8-27 PTF |
| R412013016 |  | 1/8-27 PTF                | 1/8-27 PTF |
| R412013017 |  | 1/8-27 PTF                | 1/8-27 PTF |
| R412012861 |  | 1/8-27 PTF                | 1/8-27 PTF |
| R412013011 |  | 1/8-27 PTF                | 1/8-27 PTF |
| R412013012 |  | 1/8-27 PTF                | 1/8-27 PTF |
| R412013014 |  | 1/8-27 PTF                | 1/8-27 PTF |
| R412012858 |  | 1/8-27 PTF                | 1/8-27 PTF |

| Part No.   | Compressed air connection |               |
|------------|---------------------------|---------------|
|            | Exhaust                   | Pilot Exhaust |
| R412013018 | 1/8-27 PTF                | M5            |
| R412013019 | 1/8-27 PTF                | M5            |
| R412013020 | 1/8-27 PTF                | M5            |
| R412012852 | 1/8-27 PTF                | M5            |
| R412013015 | 1/8-27 PTF                | M5            |
| R412013016 | 1/8-27 PTF                | M5            |
| R412013017 | 1/8-27 PTF                | M5            |
| R412012861 | 1/8-27 PTF                | M5            |
| R412013011 | 1/8-27 PTF                | M5            |
| R412013012 | 1/8-27 PTF                | M5            |
| R412013014 | 1/8-27 PTF                | M5            |
| R412012858 | 1/8-27 PTF                | M5            |

| Part No.   | Operational voltage |          | Operational voltage |
|------------|---------------------|----------|---------------------|
|            | DC                  | AC 50 Hz | AC 60 Hz            |
| R412013018 | 12 V                | -        | -                   |
| R412013019 | 24 V                | -        | -                   |
| R412013020 | -                   | 110 V    | 110 V               |
| R412012852 | -                   | -        | -                   |
| R412013015 | 12 V                | -        | -                   |
| R412013016 | 24 V                | -        | -                   |
| R412013017 | -                   | 110 V    | 110 V               |
| R412012861 | -                   | -        | -                   |
| R412013011 | 12 V                | -        | -                   |
| R412013012 | 24 V                | -        | -                   |
| R412013014 | -                   | 110 V    | 110 V               |
| R412012858 | -                   | -        | -                   |

| Part No.   | Voltage tolerance |          |          | Power consumption |
|------------|-------------------|----------|----------|-------------------|
|            | DC                | AC 50 Hz | AC 60 Hz | DC                |
| R412013018 | -10% / +10%       | -        | -        | 4.6 W             |

| Part No.   | Voltage tolerance | Voltage tolerance | Voltage tolerance | Power consumption |
|------------|-------------------|-------------------|-------------------|-------------------|
|            | DC                | AC 50 Hz          | AC 60 Hz          | DC                |
| R412013019 | -10% / +10%       | -                 | -                 | 4.8 W             |
| R412013020 | -                 | -20% / +10%       | -10% / +20%       | -                 |
| R412012852 | -                 | -                 | -                 | -                 |
| R412013015 | -10% / +10%       | -                 | -                 | 4.6 W             |
| R412013016 | -10% / +10%       | -                 | -                 | 4.8 W             |
| R412013017 | -                 | -20% / +10%       | -10% / +20%       | -                 |
| R412012861 | -                 | -                 | -                 | -                 |
| R412013011 | -10% / +10%       | -                 | -                 | 4.6 W             |
| R412013012 | -10% / +10%       | -                 | -                 | 4.8 W             |
| R412013014 | -                 | -20% / +10%       | -10% / +20%       | -                 |
| R412012858 | -                 | -                 | -                 | -                 |

| Part No.   | Holding power | Holding power | Switch-on power | Switch-on power |
|------------|---------------|---------------|-----------------|-----------------|
|            | AC 50 Hz      | AC 60 Hz      | AC 50 Hz        | AC 60 Hz        |
| R412013018 | -             | -             | -               | -               |
| R412013019 | -             | -             | -               | -               |
| R412013020 | 8.3 VA        | 7.2 VA        | 10.8 VA         | 9.5 VA          |
| R412012852 | -             | -             | -               | -               |
| R412013015 | -             | -             | -               | -               |
| R412013016 | -             | -             | -               | -               |
| R412013017 | 8.3 VA        | 7.2 VA        | 10.8 VA         | 9.5 VA          |
| R412012861 | -             | -             | -               | -               |
| R412013011 | -             | -             | -               | -               |
| R412013012 | -             | -             | -               | -               |
| R412013014 | 8.3 VA        | 7.2 VA        | 10.8 VA         | 9.5 VA          |
| R412012858 | -             | -             | -               | -               |

| Part No.   | basic valve with electrical connector | Weight  |
|------------|---------------------------------------|---------|
| R412013018 | -                                     | 0.49 kg |
| R412013019 | -                                     | 0.49 kg |
| R412013020 | -                                     | 0.49 kg |
| R412012852 | Basic valve without coil              | 0.39 kg |
| R412013015 | -                                     | 0.49 kg |
| R412013016 | -                                     | 0.49 kg |
| R412013017 | -                                     | 0.49 kg |
| R412012861 | Basic valve without coil              | 0.39 kg |
| R412013011 | -                                     | 0.49 kg |
| R412013012 | -                                     | 0.49 kg |
| R412013014 | -                                     | 0.49 kg |
| R412012858 | Basic valve without coil              | 0.39 kg |

Nominal flow  $Q_n$  at 6 bar and  $\Delta p = 1$  bar, MO = Manual override

## Technical information



The min. control pressure must be adhered to, since otherwise faulty switching and valve failure may result!  
The pressure dew point must be at least 15 °C under ambient and medium temperature and may not exceed 3 °C .  
The oil content of compressed air must remain constant during the life cycle.  
Use only the approved oils from AVENTICS. Further information can be found in the “Technical information” document (available in the MediaCentre).

## Technical information

| Material |  |
|----------|--|
| Housing  | Die cast zinc Polyamide fiber-glass reinforced |
| Seals    | Acrylonitrile butadiene rubber                 |

# Dimensions

## Dimensions in inches

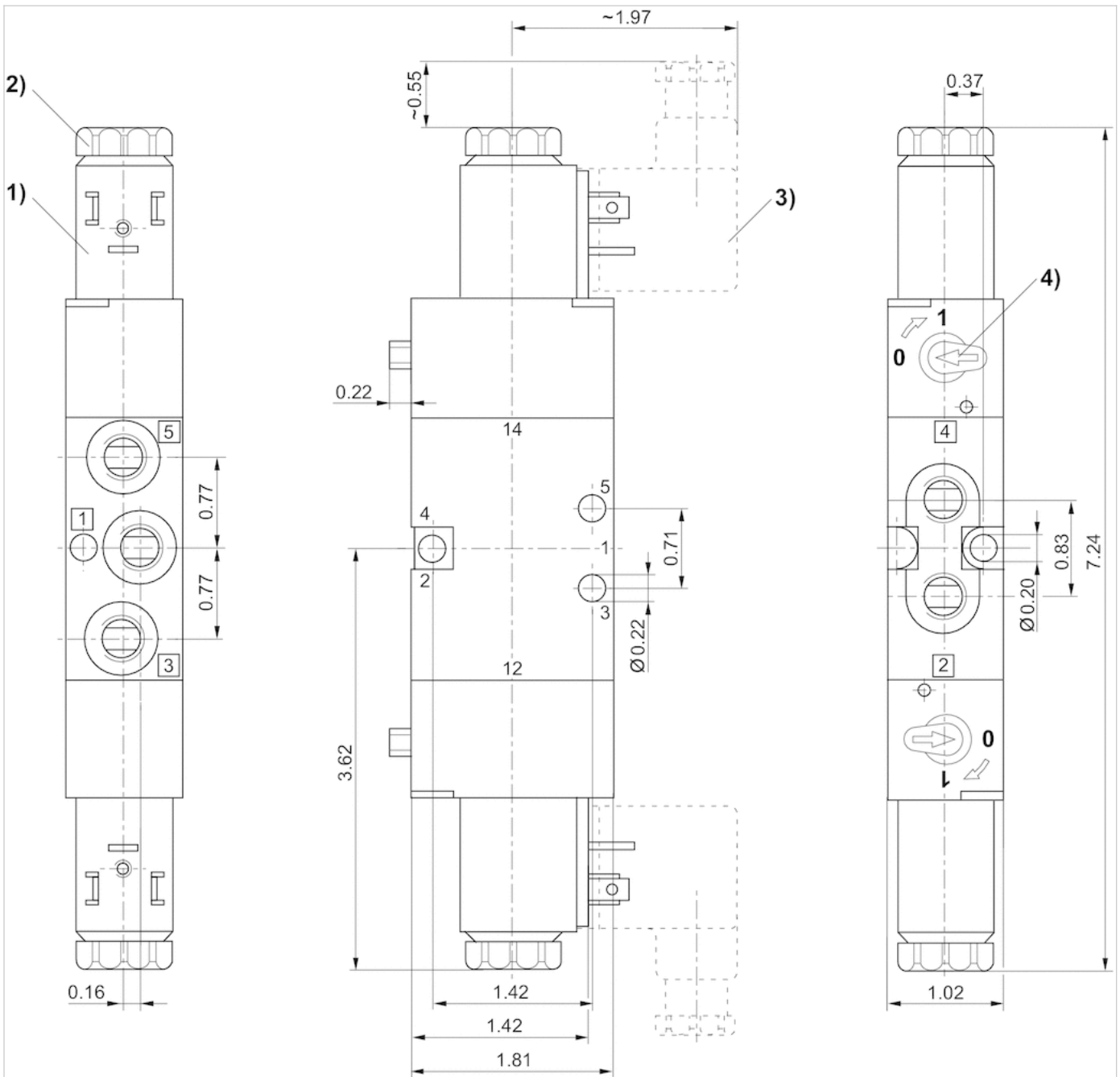

1) Coil can be rotated at 90° intervals 2) After removal of cap M5 internal thread 3) Valve plug connector can be plugged at 180° intervals 4) Manual override

# 3/2-directional valve, Series CD04

- $Q_n = 900$  l/min
- Compressed air connection output 1/8-27 NPTF
- Single air pilot
- Pipe connection



|                               |                                   |
|-------------------------------|-----------------------------------|
| Version                       | Spool valve, positive overlapping |
| Activation                    | pneumatically                     |
| Sealing principle             | Soft sealing                      |
| Compressed air connection     | according to ANSI B1.20.3         |
| Flow rate value $Q_n$         | 900 l/min                         |
| Working pressure min./max.    | -0.95 ... 10 bar                  |
| Control pressure min./max.    | 3.5 ... 10 bar                    |
| Ambient temperature min./max. | -15 ... 65 °C                     |
| Medium temperature min./max.  | -15 ... 65 °C                     |
| Medium                        | Compressed air                    |
| Max. particle size            | 50 $\mu\text{m}$                  |
| Oil content of compressed air | 0 ... 1 mg/m <sup>3</sup>         |
| Weight                        | 0.29 kg                           |

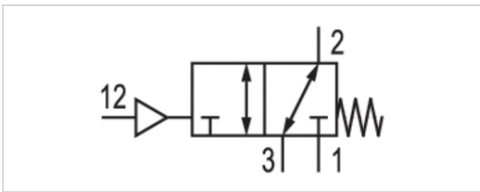

## Technical data

| Part No.   |       | Compressed air connection |             |
|------------|-------|---------------------------|-------------|
|            |       | Input                     | Output      |
| R412013298 | NC/NO | 1/8-27 NPTF               | 1/8-27 NPTF |

| Part No.   | Compressed air connection |                       |
|------------|---------------------------|-----------------------|
|            | Exhaust                   | Pilot control exhaust |
| R412013298 | 1/8-27 NPTF               | 1/8-27 NPTF           |

Nominal flow  $Q_n$  at 6 bar and  $\Delta p = 1$  bar

## Technical information

The min. control pressure must be adhered to, since otherwise faulty switching and valve failure may result!  
 The pressure dew point must be at least 15 °C under ambient and medium temperature and may not exceed 3 °C .  
 The oil content of compressed air must remain constant during the life cycle.  
 Use only the approved oils from AVENTICS. Further information can be found in the "Technical information" document (available in the MediaCentre).

## Technical information

| Material |  |
|----------|--|
| Housing  | Die cast zinc Polyamide fiber-glass reinforced |
| Seals    | Acrylonitrile butadiene rubber                 |

# Dimensions

## Dimensions in inches

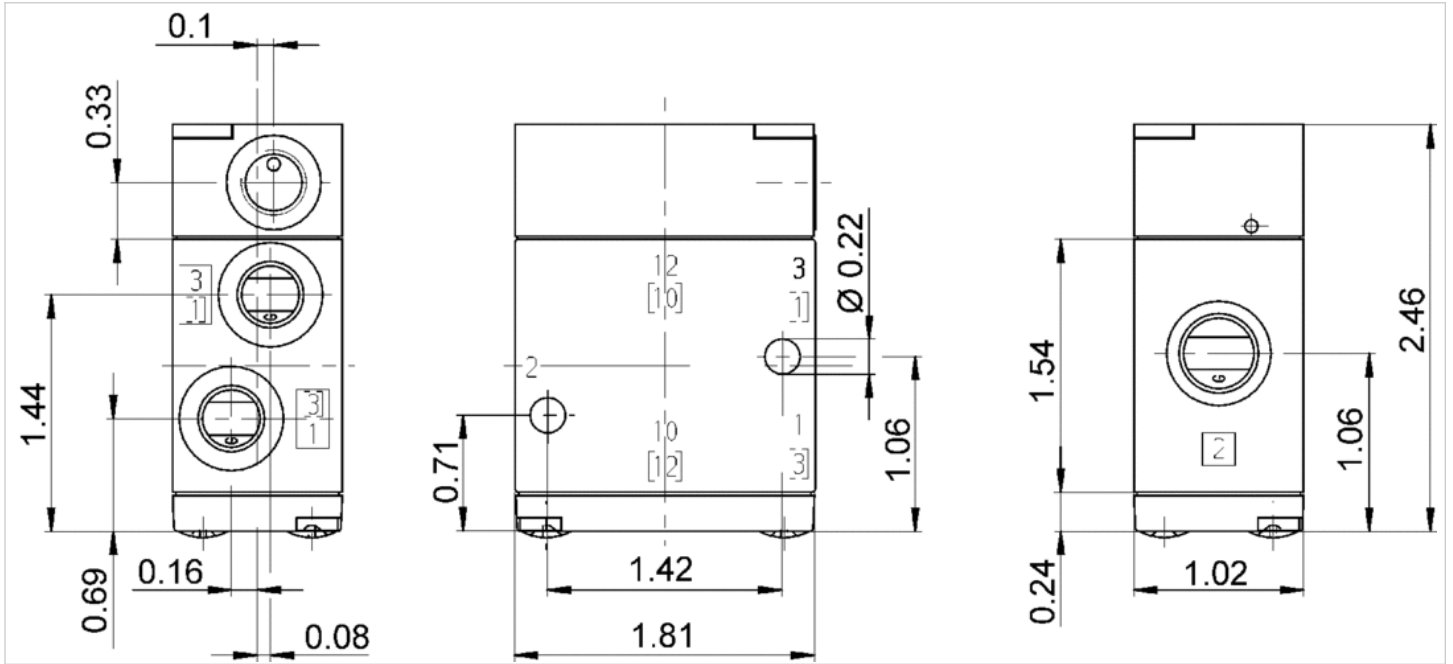

# 5/2-directional valve, Series CD04

- Qn = 900 l/min
- Compressed air connection output 1/8-27 NPTF
- Single air pilot
- Pipe connection



|                               |                                   |
|-------------------------------|-----------------------------------|
| Version                       | Spool valve, positive overlapping |
| Activation                    | pneumatically                     |
| Sealing principle             | Soft sealing                      |
| Compressed air connection     | according to ANSI B1.20.3         |
| Flow rate value Qn            | 900 l/min                         |
| Working pressure min./max.    | -0.95 ... 10 bar                  |
| Control pressure min./max.    | 3.5 ... 10 bar                    |
| Ambient temperature min./max. | -15 ... 65 °C                     |
| Medium temperature min./max.  | -15 ... 65 °C                     |
| Medium                        | Compressed air                    |
| Max. particle size            | 50 µm                             |
| Oil content of compressed air | 0 ... 1 mg/m <sup>3</sup>         |
| Mounting on manifold strip    | P-strip                           |
| Weight                        | 0.31 kg                           |

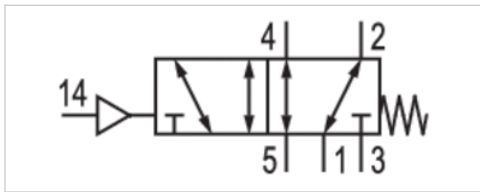

## Technical data

| Part No.   | Compressed air connection |             |
|------------|---------------------------|-------------|
|            | Input                     | Output      |
| R412013299 | 1/8-27 NPTF               | 1/8-27 NPTF |

| Part No.   | Compressed air connection |                       |
|------------|---------------------------|-----------------------|
|            | Exhaust                   | Pilot control exhaust |
| R412013299 | 1/8-27 NPTF               | 1/8-27 NPTF           |

Nominal flow Qn at 6 bar and  $\Delta p = 1$  bar

## Technical information

The min. control pressure must be adhered to, since otherwise faulty switching and valve failure may result!  
 The pressure dew point must be at least 15 °C under ambient and medium temperature and may not exceed 3 °C .  
 The oil content of compressed air must remain constant during the life cycle.  
 Use only the approved oils from AVENTICS. Further information can be found in the "Technical information" document (available in the MediaCentre).

## Technical information

| Material |  |
|----------|--|
| Housing  | Die cast zinc Polyamide fiber-glass reinforced |
| Seals    | Acrylonitrile butadiene rubber                 |

# Dimensions

## Dimensions in inches

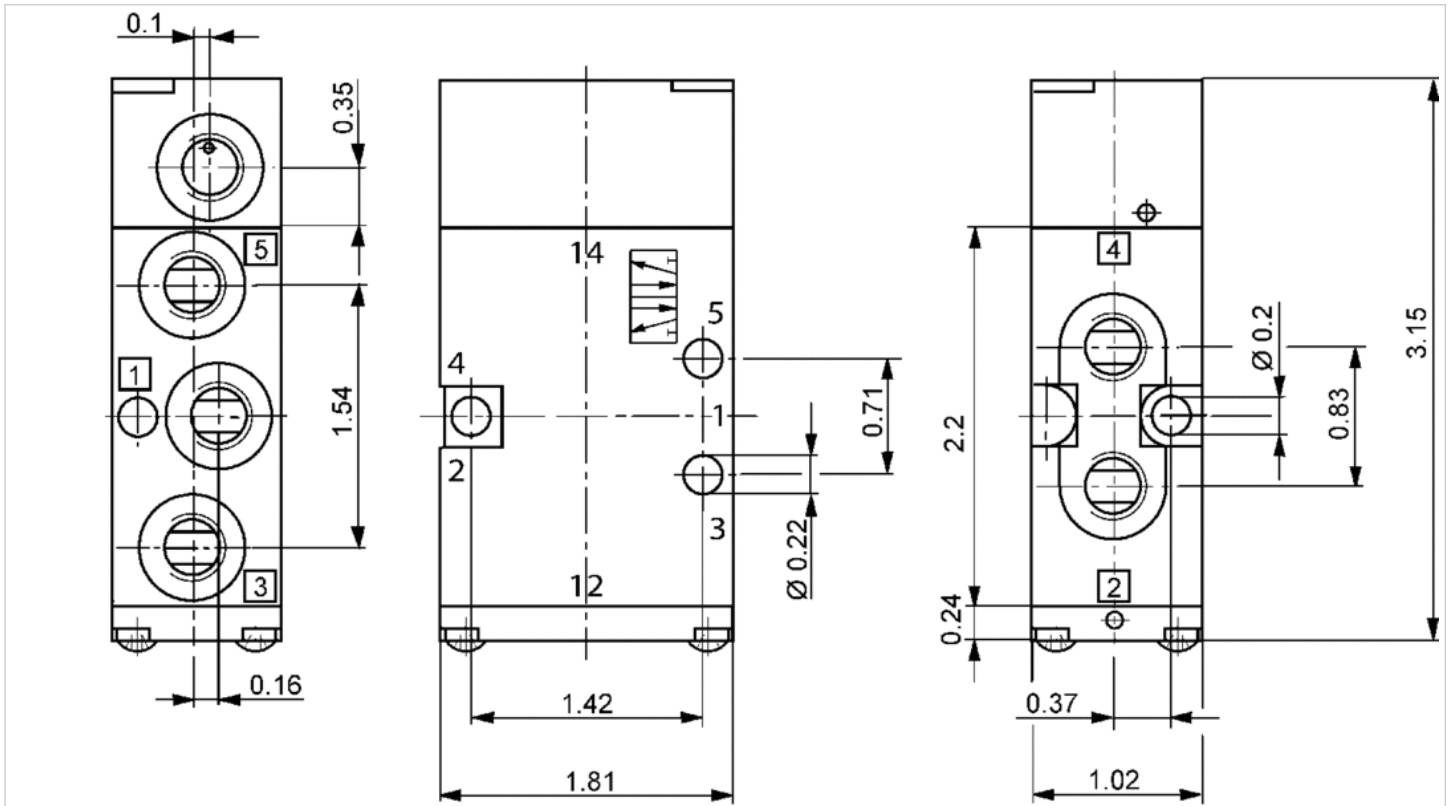

# 5/2-directional valve, Series CD04

- Qn = 900 l/min
- Compressed air connection output 1/8-27 NPTF
- double air pilot
- Pipe connection



|                               |                                   |
|-------------------------------|-----------------------------------|
| Version                       | Spool valve, positive overlapping |
| Activation                    | pneumatically                     |
| Sealing principle             | Soft sealing                      |
| Compressed air connection     | according to ANSI B1.20.3         |
| Flow rate value Qn            | 900 l/min                         |
| Working pressure min./max.    | -0.95 ... 10 bar                  |
| Control pressure min./max.    | 2 ... 10 bar                      |
| Ambient temperature min./max. | -15 ... 65 °C                     |
| Medium temperature min./max.  | -15 ... 65 °C                     |
| Medium                        | Compressed air                    |
| Max. particle size            | 50 µm                             |
| Oil content of compressed air | 0 ... 1 mg/m <sup>3</sup>         |
| Mounting on manifold strip    | P-strip                           |
| Weight                        | 0.3 kg                            |

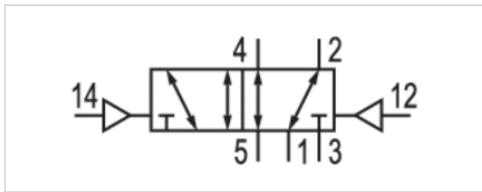

## Technical data

| Part No.   | Compressed air connection |             |
|------------|---------------------------|-------------|
|            | Input                     | Output      |
| R412013300 | 1/8-27 NPTF               | 1/8-27 NPTF |

| Part No.   | Compressed air connection |                       |
|------------|---------------------------|-----------------------|
|            | Exhaust                   | Pilot control exhaust |
| R412013300 | 1/8-27 NPTF               | 1/8-27 NPTF           |

Nominal flow Qn at 6 bar and Δp = 1 bar

## Technical information

The min. control pressure must be adhered to, since otherwise faulty switching and valve failure may result!  
 The pressure dew point must be at least 15 °C under ambient and medium temperature and may not exceed 3 °C .  
 The oil content of compressed air must remain constant during the life cycle.  
 Use only the approved oils from AVENTICS. Further information can be found in the “Technical information” document (available in the MediaCentre).

## Technical information

| Material |  |
|----------|--|
| Housing  | Die cast zinc Polyamide fiber-glass reinforced |
| Seals    | Acrylonitrile butadiene rubber                 |

# Dimensions

## Dimensions in inches

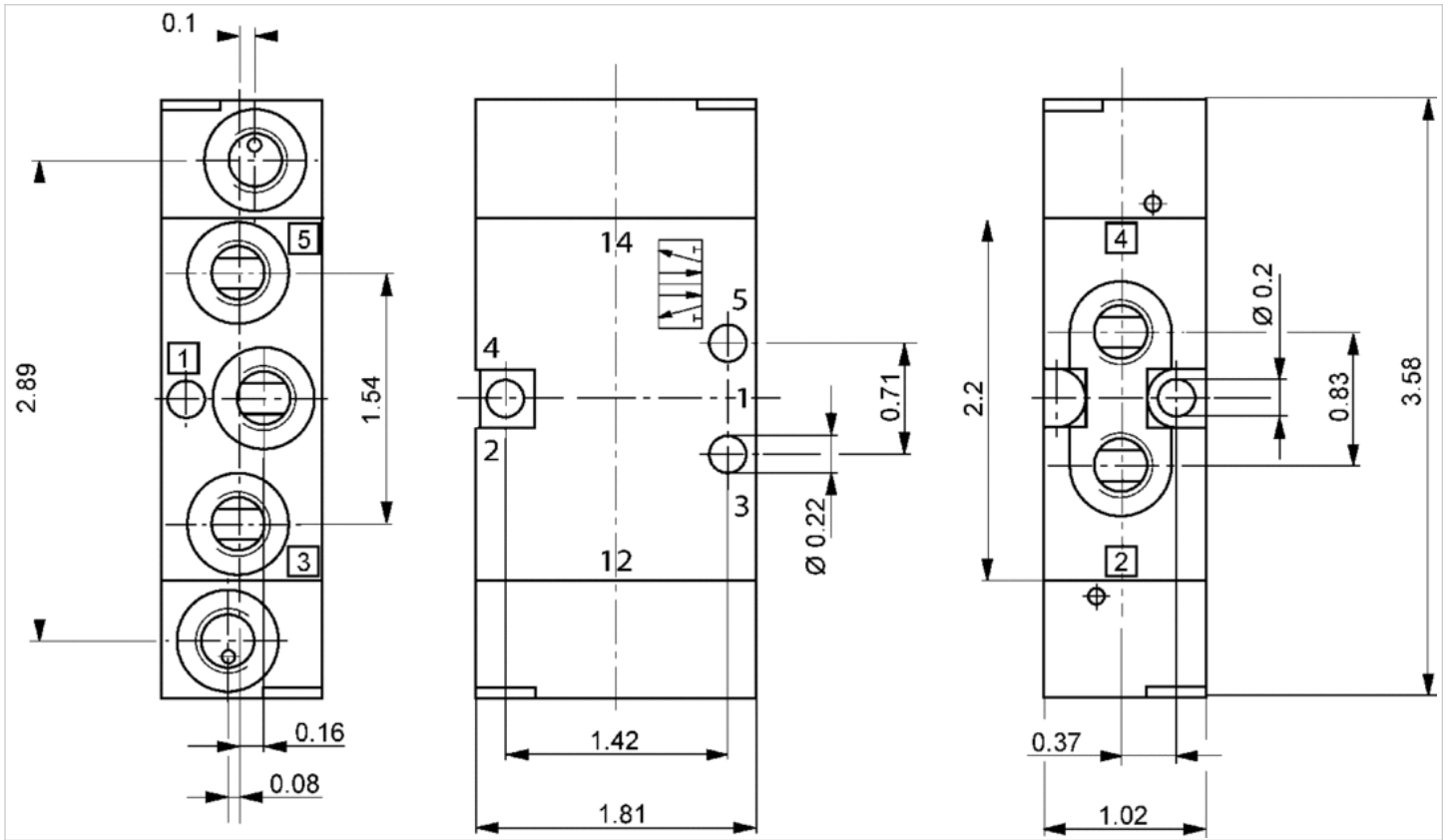









# 3/2-directional valve, Series CD04 - inch

- Qn = 900 l/min
- Compressed air connection output 1/8-27 NPTF
- single solenoid
- Pipe connection



|                               |                                   |
|-------------------------------|-----------------------------------|
| Version                       | Spool valve, positive overlapping |
| Activation                    | Mechanical                        |
| Switching principle           | 3/2                               |
| Sealing principle             | Soft sealing                      |
| Nominal flow Qn               | 900 l/min                         |
| Working pressure min./max.    | -0.95 ... 10 bar                  |
| Ambient temperature min./max. | -20 ... 65 °C                     |
| Medium temperature min./max.  | -20 ... 65 °C                     |
| Medium                        | Compressed air                    |
| Max. particle size            | 50 µm                             |
| Oil content of compressed air | 0 ... 1 mg/m <sup>3</sup>         |
| Weight                        | See table below                   |

## Technical data

| Part No.   |   | Actuating element                       | Version | Compressed air connection type |
|------------|---|---|---------|--------------------------------|
| R412013026 |  | Plunger                                 | NC/NO   | Internal thread                |
| R412013021 |  | Roller                                  | NC/NO   | Internal thread                |
| R412013022 |  | Roller                                  | NC/NO   | Internal thread                |
| R412013025 |  | Hand lever, with detent, without detent | NC/NO   | Internal thread                |
| R412013023 |  | Hand lever                              | NC/NO   | Internal thread                |
| R412013024 |  | Rotary lever, with detent               | NC/NO   | Internal thread                |
| R412013027 |  | Button                                  | NC/NO   | Internal thread                |

| Part No.   | Compressed air connection Input | Compressed air connection Output | Compressed air connection Exhaust |
|------------|---------------------------------|----------------------------------|-----------------------------------|
| R412013026 | 1/8-27 NPTF                     | 1/8-27 NPTF                      | 1/8-27 NPTF                       |
| R412013021 | 1/8-27 NPTF                     | 1/8-27 NPTF                      | 1/8-27 NPTF                       |
| R412013022 | 1/8-27 NPTF                     | 1/8-27 NPTF                      | 1/8-27 NPTF                       |
| R412013025 | 1/8-27 NPTF                     | 1/8-27 NPTF                      | 1/8-27 NPTF                       |
| R412013023 | 1/8-27 NPTF                     | 1/8-27 NPTF                      | 1/8-27 NPTF                       |
| R412013024 | 1/8-27 NPTF                     | 1/8-27 NPTF                      | 1/8-27 NPTF                       |
| R412013027 | 1/8-27 NPTF                     | 1/8-27 NPTF                      | 1/8-27 NPTF                       |

| Part No.   | Operating force | Material actuating control | Weight  | Fig.   |
|------------|-----------------|----------------------------|---------|--------|
|            | min.            |                            |         |        |
| R412013026 | 60 N            | Stainless steel            | 0.23 kg | Fig. 1 |
| R412013021 | 30 N            | Polyoxymethylene           | 0.29 kg | Fig. 2 |
| R412013022 | 30 N            | Stainless steel            | 0.29 kg | Fig. 2 |
| R412013025 | 15 N            | Polyoxymethylene           | 0.32 kg | Fig. 3 |
| R412013023 | 15 N            | Aluminum                   | 0.29 kg | Fig. 4 |
| R412013024 | 15 N            | Stainless steel Plastic    | 0.5 kg  | Fig. 5 |
| R412013027 | 60 N            | Polyoxymethylene           | 0.25 kg | Fig. 6 |

Nominal flow Qn at 6 bar and Δp = 1 bar

## Technical information

|                   |  |
|-------------------|--|
| Material          |  |
| Actuating element | Stainless steel Polyoxymethylene Aluminum Stainless steel, Plastic |

## Dimensions

Dimensions in inches, Fig. 1, Basic valve

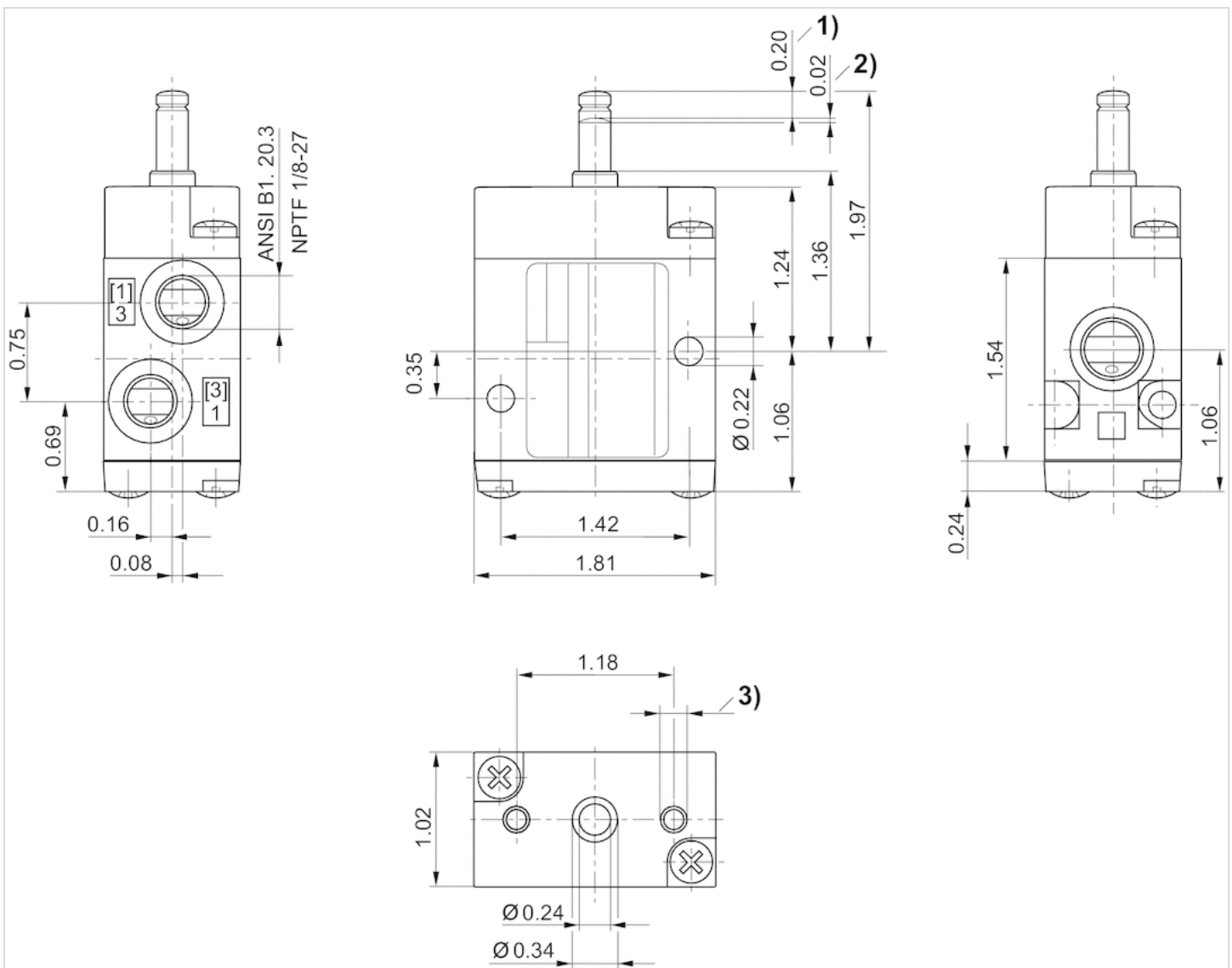

1) Stroke 2) Overstroke 3) Ø 0.18 - 0.47 mm deep

## Dimensions in inches, Fig. 2

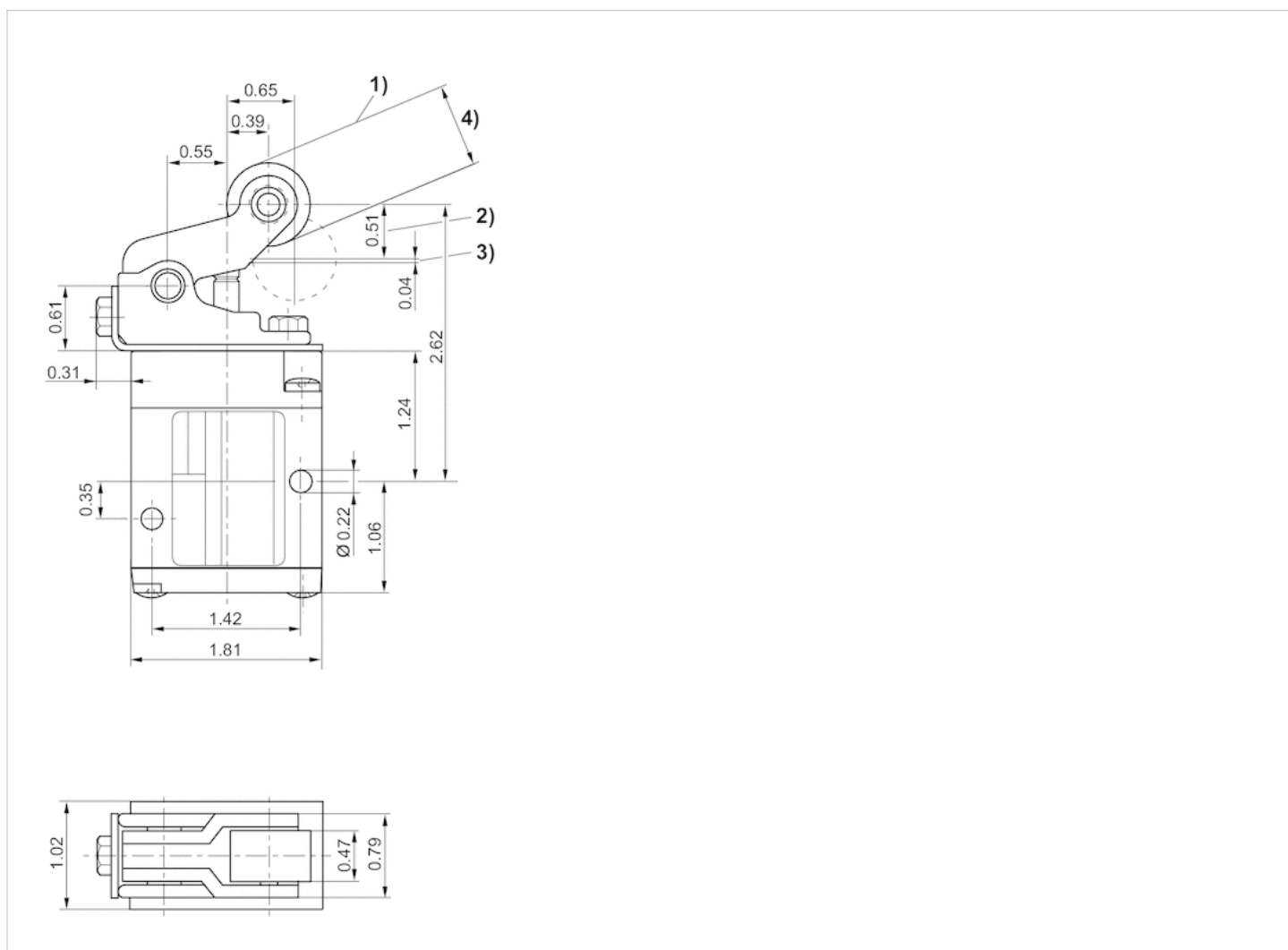

- 1) approach angle of rollers max. 30° 2) stroke 3) overstroke  
4) R412013021: Ø 0,79 (POM) / R412013022: Ø 0,75 (ST)

Dimensions in inches, Fig. 3

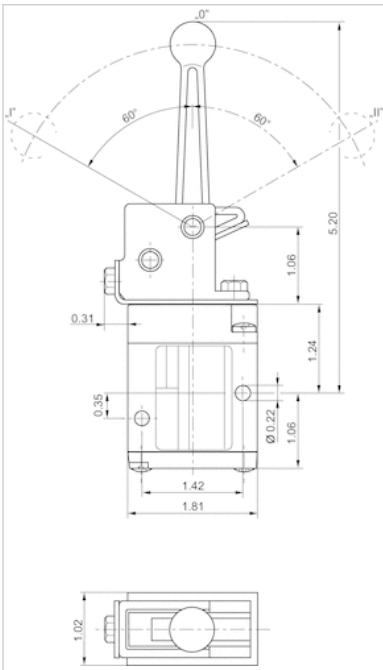

Position 0: initial position, position I: with detent, manual return, position II: automatic spring return.

Dimensions in inches, Fig. 4

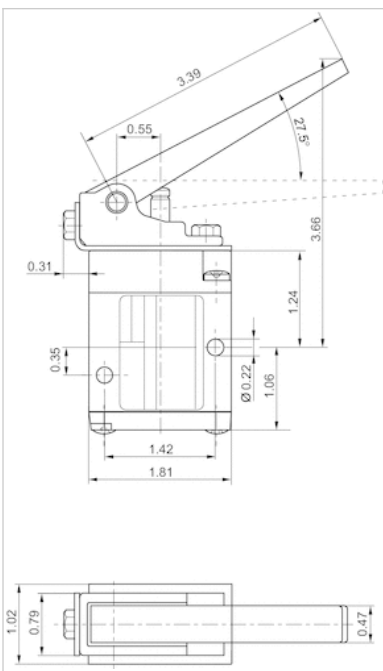

Dimensions of basic valve apply to all types of actuation.

Dimensions in inches, Fig. 5

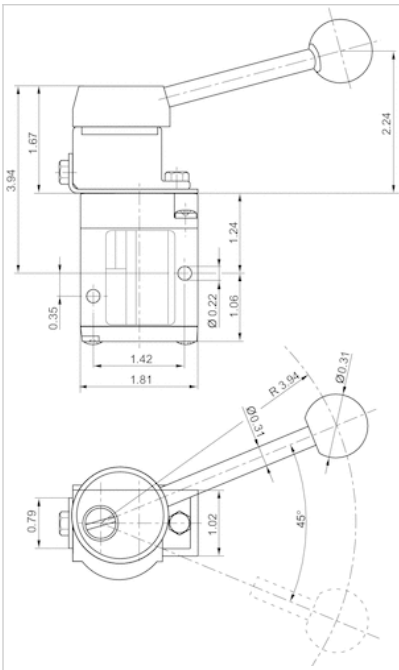

Dimensions of basic valve apply to all types of actuation.

Dimensions in inches, Fig. 6

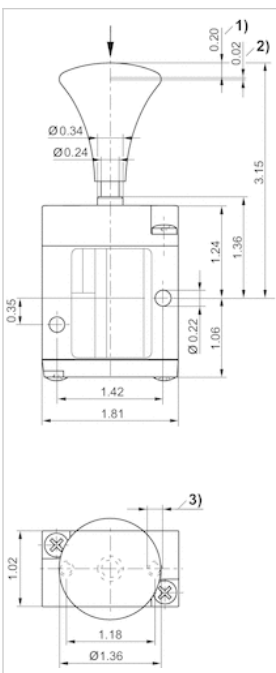

1) Stroke 2) Overstroke 3) Ø 0.18 - 0.47 mm deep







# 5/2-directional valve, Series CD04 - inch

- Qn = 900 l/min
- Compressed air connection output 1/8-27 NPTF
- single solenoid
- Pipe connection



|                               |                                   |
|-------------------------------|-----------------------------------|
| Version                       | Spool valve, positive overlapping |
| Activation                    | Mechanical                        |
| Switching principle           | 5/2                               |
| Sealing principle             | Soft sealing                      |
| Nominal flow Qn               | 900 l/min                         |
| Working pressure min./max.    | -0.95 ... 10 bar                  |
| Ambient temperature min./max. | -20 ... 65 °C                     |
| Medium temperature min./max.  | -20 ... 65 °C                     |
| Medium                        | Compressed air                    |
| Max. particle size            | 50 µm                             |
| Oil content of compressed air | 0 ... 1 mg/m <sup>3</sup>         |
| Weight                        | See table below                   |

## Technical data

| Part No.   |   | Actuating element                       | Compressed air connection type |
|------------|---|---|--------------------------------|
| R412013032 |  | Plunger                                 | Internal thread                |
| R412013028 |  | Roller                                  | Internal thread                |
| R412013031 |  | Hand lever, with detent, without detent | Internal thread                |
| R412013029 |  | Hand lever                              | Internal thread                |
| R412013030 |  | Rotary lever, with detent               | Internal thread                |
| R412013033 |  | Button                                  | Internal thread                |

| Part No.   | Compressed air connection Input | Compressed air connection Output | Compressed air connection Exhaust |
|------------|---------------------------------|----------------------------------|-----------------------------------|
| R412013032 | 1/8-27 NPTF                     | 1/8-27 NPTF                      | 1/8-27 NPTF                       |
| R412013028 | 1/8-27 NPTF                     | 1/8-27 NPTF                      | 1/8-27 NPTF                       |
| R412013031 | 1/8-27 NPTF                     | 1/8-27 NPTF                      | 1/8-27 NPTF                       |
| R412013029 | 1/8-27 NPTF                     | 1/8-27 NPTF                      | 1/8-27 NPTF                       |
| R412013030 | 1/8-27 NPTF                     | 1/8-27 NPTF                      | 1/8-27 NPTF                       |
| R412013033 | 1/8-27 NPTF                     | 1/8-27 NPTF                      | 1/8-27 NPTF                       |

| Part No.   | Operating force | Material actuating control | Weight  | Fig.   |
|------------|-----------------|----------------------------|---------|--------|
|            | min.            |                            |         |        |
| R412013032 | 70 N            | Stainless steel            | 0.29 kg | Fig. 1 |
| R412013028 | 35 N            | Polyoxymethylene           | 0.35 kg | Fig. 2 |
| R412013031 | 15 N            | Polyoxymethylene           | 0.38 kg | Fig. 3 |
| R412013029 | 60 N            | Aluminum                   | 0.36 kg | Fig. 4 |
| R412013030 | 20 N            | Stainless steel Plastic    | 0.56 kg | Fig. 5 |
| R412013033 | 70 N            | Polyoxymethylene           | 0.32 kg | Fig. 6 |

Nominal flow Qn at 6 bar and  $\Delta p = 1$  bar

## Technical information

| Material          |  |
|-------------------|--|
| Housing           | Die cast zinc Polyamide fiber-glass reinforced                     |
| Seals             | Acrylonitrile butadiene rubber                                     |
| Actuating element | Stainless steel Polyoxymethylene Aluminum Stainless steel, Plastic |

## Dimensions

Dimensions in inches, Fig. 1

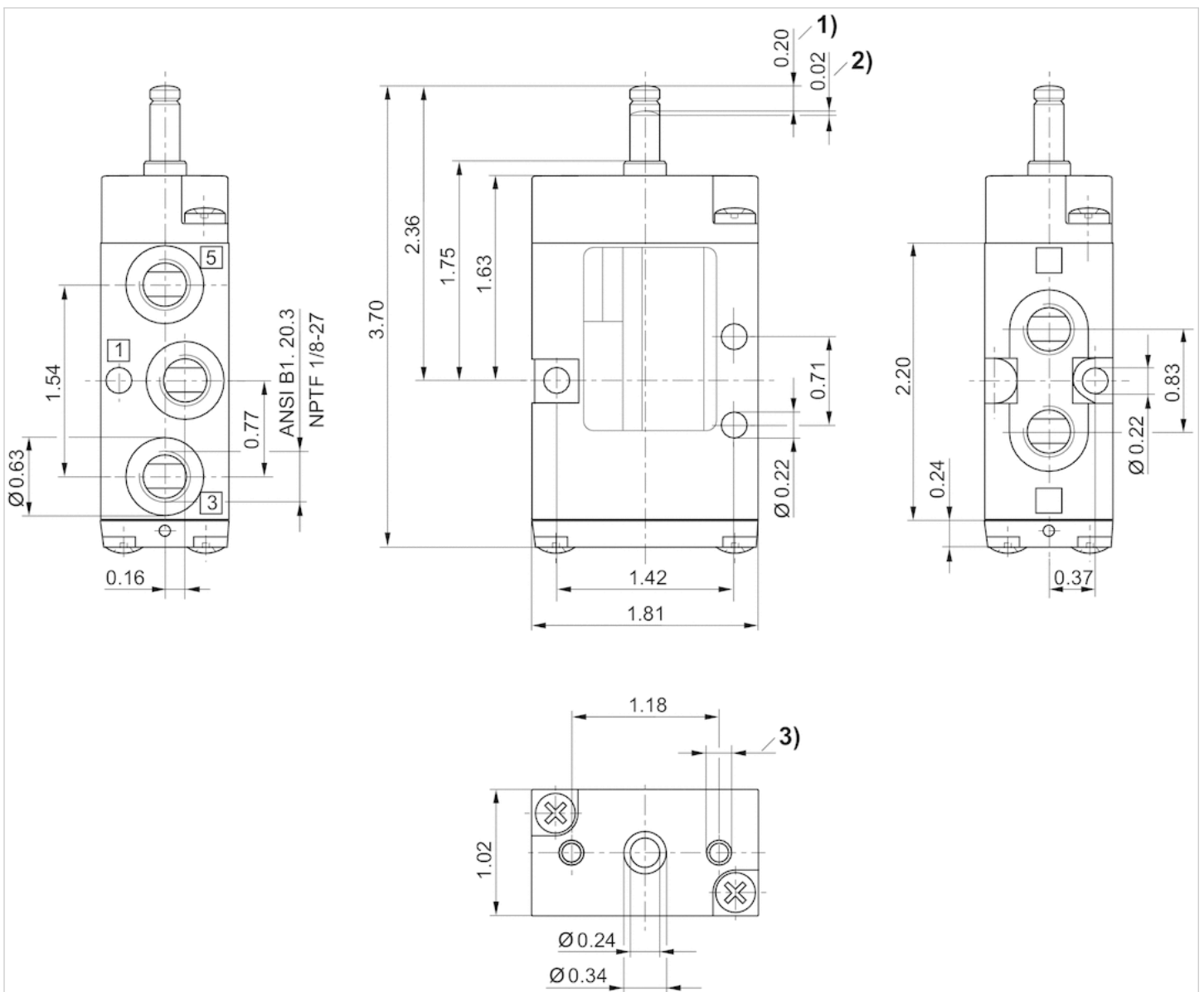

1) Stroke 2) Overstroke 3)  $\text{Ø}0.18 - 0.47$  mm deep

Dimensions in inches, Fig. 2

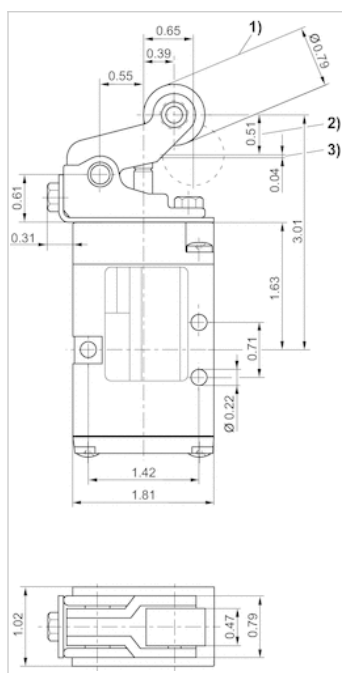

1) approach angle of rollers max. 30° 2) stroke 3) overstroke

Dimensions in inches, Fig. 3

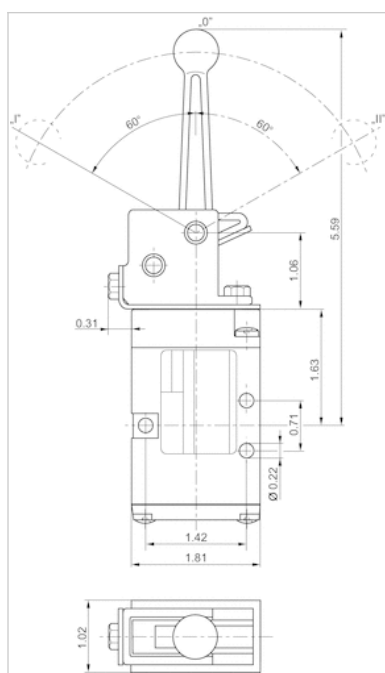

Position 0: initial position, position I: with detent, manual return, position II: automatic spring return.



Dimensions in inches, Fig. 4

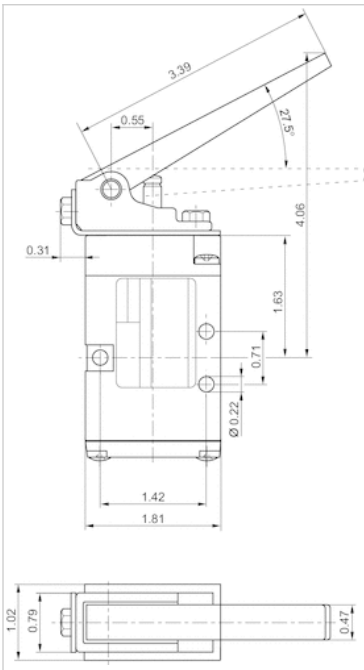

Dimensions in inches, Fig. 5

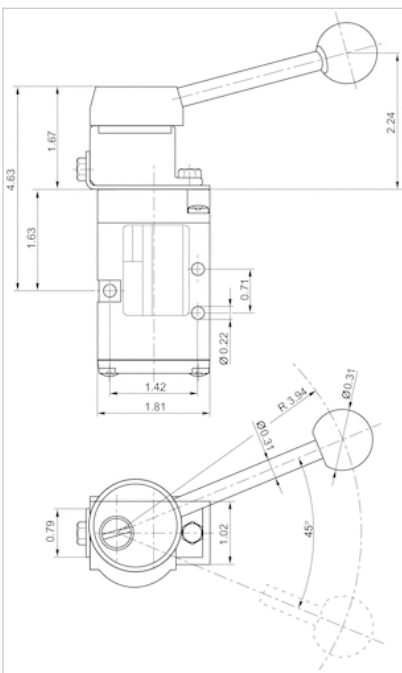

Dimensions in inches, Fig. 6

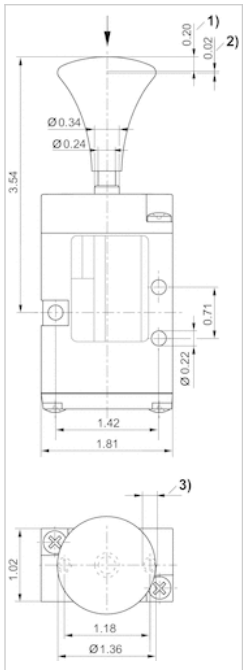

1) Stroke 2) Overstroke 3) Ø 0.18 - 0.47 mm deep

# Coil, Series C01

- form B
- Coil width 22 mm
- Power consumption DC 2.6-5.9 W
- Holding power AC 7.7-9.7 VA
- Switch-on power AC 10.5-12.6 VA



|   |                       |
|---|-----------------------|
| Connector standard                              | EN 175301-803, form B |
| electrical connections                          | Plug, 3-pin           |
| Ambient temperature min./max.                   | 50 °C                 |
| Protection class With valve plug connector/plug | IP65                  |
| Duty cycle ED                                   | 100 %                 |
| Weight  | 0.07 kg               |

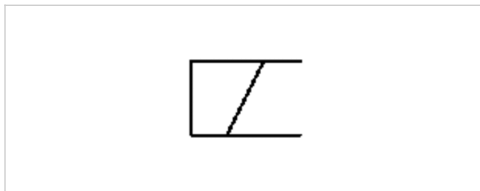

## Technical data

| Part No.   | Operational voltage | Operational voltage | Operational voltage |
|------------|---------------------|---------------------|---------------------|
|            | DC                  | AC 50 Hz            | AC 60 Hz            |
| 1824210245 | 24 V                | -                   | -                   |
| 1824210239 | 12 V                | 24 V                | 24 V                |
| 1824210243 | 24 V                | 48 V                | 48 V                |
| 1824210241 | 48 V                | -                   | -                   |
| 1824210237 | 60 V                | 110 V               | 110 V               |
| 1824210235 | 110 V               | 220 V               | 230 V               |

| Part No.   | Voltage tolerance | Voltage tolerance | Voltage tolerance | Power consumption |
|------------|-------------------|-------------------|-------------------|-------------------|
|            | DC                | AC 50 Hz          | AC 60 Hz          | DC                |
| 1824210245 | -10% / +10%       | -10% / +10%       | -10% / +10%       | 2.6 W             |
| 1824210239 | -10% / +10%       | -10% / +10%       | -10% / +10%       | 5.5 W             |
| 1824210243 | -10% / +10%       | -10% / +10%       | -10% / +10%       | 4.8 W             |
| 1824210241 | -10% / +10%       | -10% / +10%       | -10% / +10%       | 5 W               |
| 1824210237 | -10% / +10%       | -10% / +10%       | -10% / +10%       | 5.9 W             |
| 1824210235 | -10% / +10%       | -10% / +10%       | -10% / +10%       | 4.9 W             |

| Part No.   | Holding power | Holding power | Switch-on power | Switch-on power |
|------------|---------------|---------------|-----------------|-----------------|
|            | AC 50 Hz      | AC 60 Hz      | AC 50 Hz        | AC 60 Hz        |
| 1824210245 | -             | -             | -               | -               |
| 1824210239 | 8.9 VA        | 7.3 VA        | 12 VA           | 9.9 VA          |

| Part No.   | Holding power | Holding power | Switch-on power | Switch-on power |
|------------|---------------|---------------|-----------------|-----------------|
|            | AC 50 Hz      | AC 60 Hz      | AC 50 Hz        | AC 60 Hz        |
| 1824210243 | 7.7 VA        | 6.2 VA        | 10.5 VA         | 9.4 VA          |
| 1824210241 | -             | -             | -               | -               |
| 1824210237 | 8.4 VA        | 6.8 VA        | 11 VA           | 9.4 VA          |
| 1824210235 | 9.7 VA        | 7.9 VA        | 12.6 VA         | 10.2 VA         |

| Part No.   | Compatibility index |
|------------|---------------------|
| 1824210245 | 13                  |
| 1824210239 | 14                  |
| 1824210243 | 14                  |
| 1824210241 | 14                  |
| 1824210237 | 14                  |
| 1824210235 | 14                  |

## Technical information

| Material |                         |
|----------|-------------------------|
| Housing  | Thermoplastic elastomer |

# Dimensions

## Dimensions

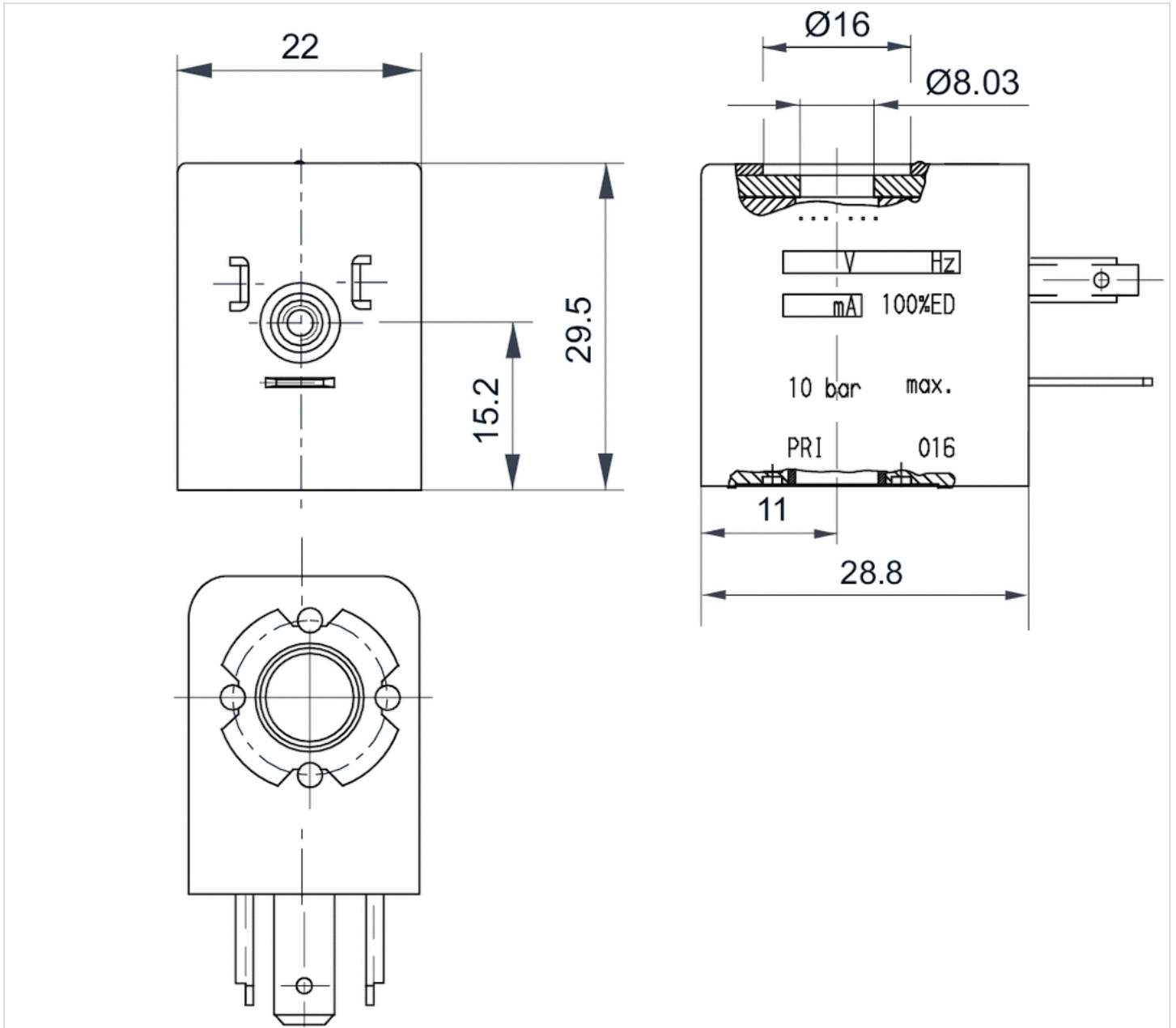

# Valve plug connector, series CON-VP

- Socket, form B, 2+E, angled, 90°
- ISO 6952
- unshielded
- with LED Yellow Red, Red



|                                  |                 |
|----------------------------------|-----------------|
| Connection type                  | Screws          |
| Ambient temperature min./max.    | -25 ... 50 °C   |
| Operational voltage              | See table below |
| Protection class                 | IP65            |
| Mounting screw tightening torque | 0.4 Nm          |
| Weight                           | 0.02 kg         |

## Technical data

| Part No.   |  | Operational voltage | Max. current | Protective circuit | Contact assignment |
|------------|--|---------------------|--------------|--------------------|--------------------|
| 1834484096 |  | -                   | 10 A         | -                  | 2+E                |
| 1834484104 |  | 24 V AC/DC          | -            | Z-diode            | 2+E                |
| 1834484105 |  | 110 V AC            | -            | Varistor           | 2+E                |
| 1834484106 |  | 230 V AC            | -            | Varistor           | 2+E                |

| Part No.   | LED status display | suitable cable-Ø min./max | Seal                            | Fig.   |
|------------|--------------------|---------------------------|---------------------------------|--------|
| 1834484096 | -                  | 5 / 8 mm                  | caoutchouc/butadiene caoutchouc | Fig. 1 |
| 1834484104 | Yellow             | 6 / 8 mm                  | Silicone caoutchouc             | Fig. 2 |
| 1834484105 | Red, Red           | 6 / 8 mm                  | Silicone caoutchouc             | Fig. 2 |
| 1834484106 | Red, Red           | 6 / 8 mm                  | Silicone caoutchouc             | Fig. 2 |

Profile seal, Flat gasket

## Technical information

The specified protection class is only valid in assembled and tested state.

## Technical information

| Material |   |
|----------|---|
| Seals    | caoutchouc/butadiene caoutchouc Silicone caoutchouc |

# Dimensions

Fig. 1

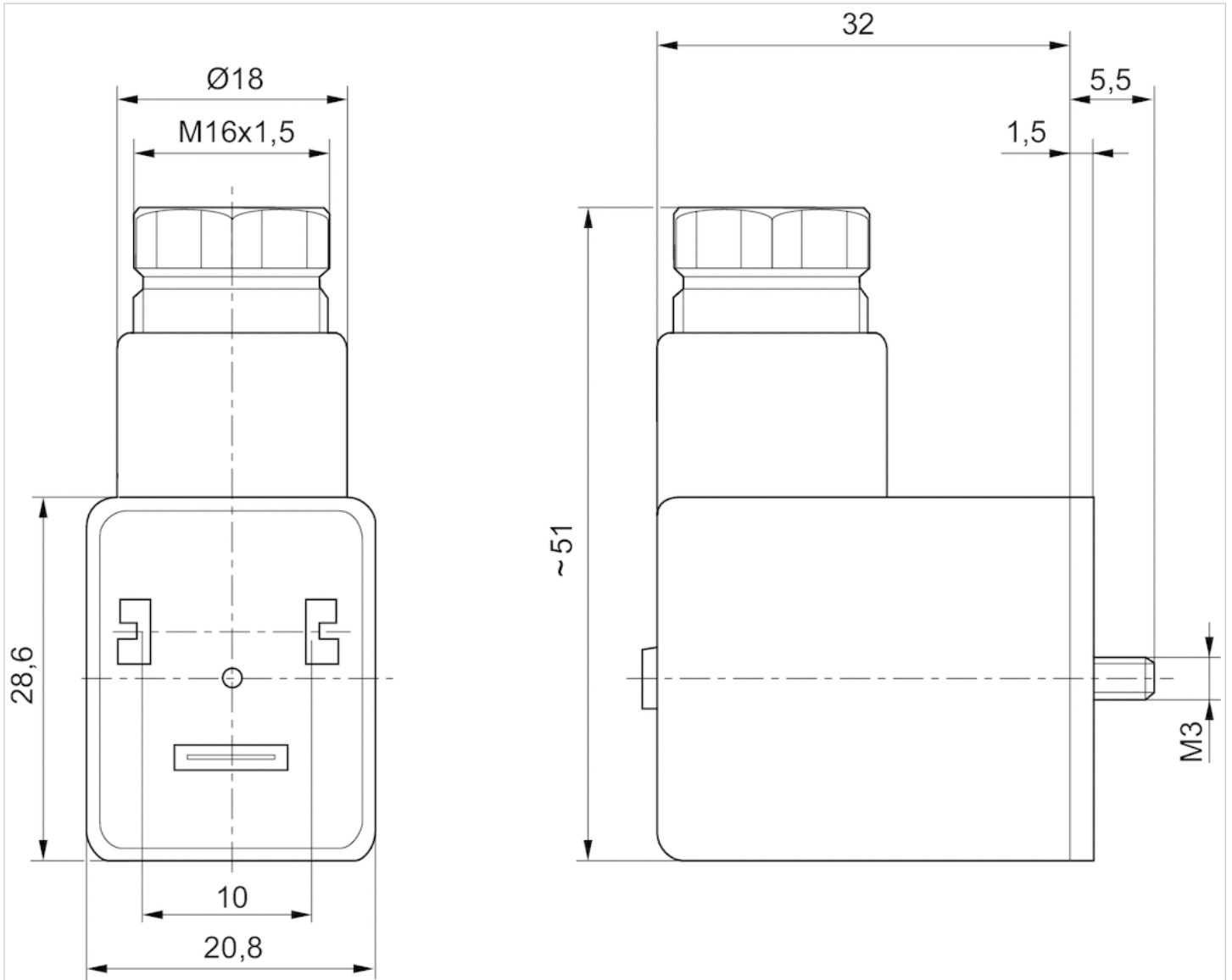
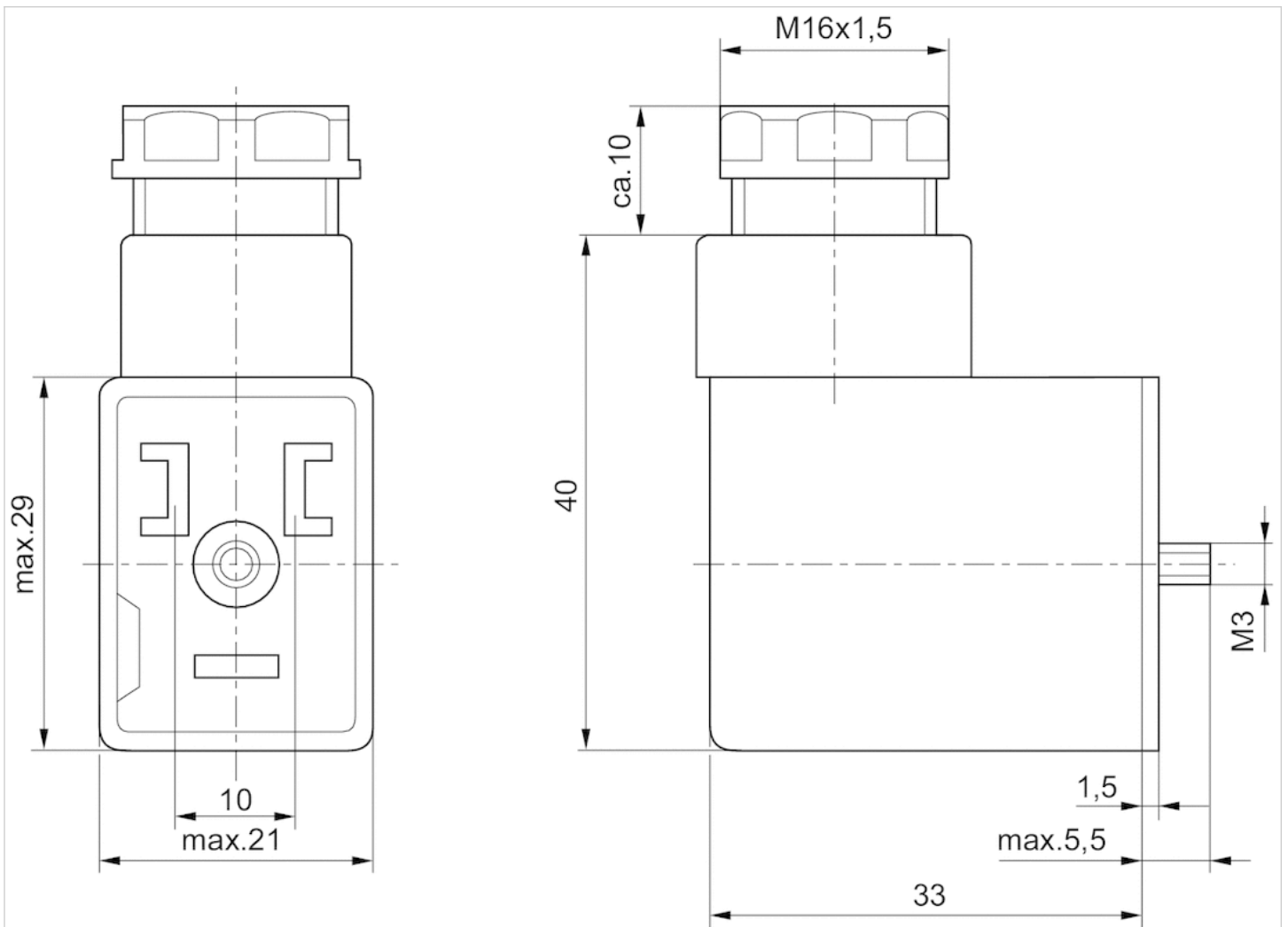

Fig. 2





# Silencers, series SI1

- M5
- Sintered bronze



|                               |   |
|-------------------------------|---|
| Working pressure min./max.    | 0 ... 10 bar  |
| Ambient temperature min./max. | -25 ... 80 °C   |
| Medium                        | Compressed air  |
| Sound pressure level          | 72 dB   |
| Weight                        | 0.004 kg  |
| Comment                       | Flow characteristic curves can be found under "Diagrams". |

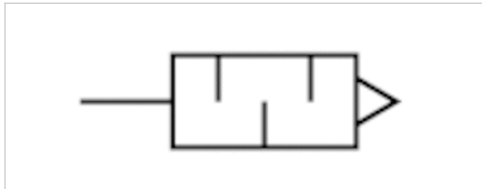

## Technical data

| Part No.   | Compressed air connection | Flow      | Delivery unit |
|------------|---------------------------|-----------|---------------|
|            |                           | Qn        |               |
| 1827000006 | M5                        | 398 l/min | 10 piece      |

Weight per piece

Nominal flow Qn at p1 = 6 bar (absolute) freely discharged. Sound pressure level measured at 6 bar against atmosphere at 1 m distance.

## Technical information

| Material |                 |
|----------|-----------------|
| Silencer | Sintered bronze |
| Thread   | Brass           |

## Dimensions

### Dimensions in mm

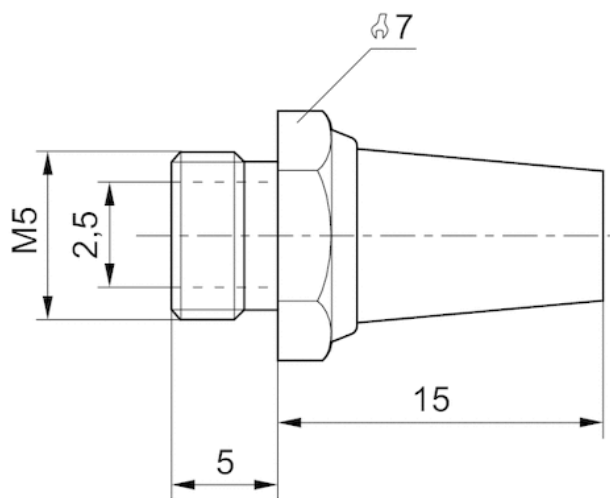

## Diagrams

### Flow diagram, 1827000006

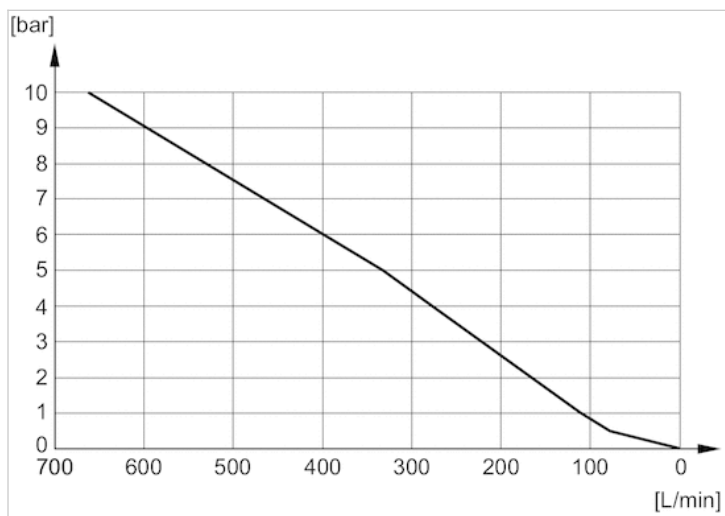

# Silencers, series SI1

- M7
- Sintered bronze



|                               |   |
|-------------------------------|---|
| Working pressure min./max.    | 0 ... 10 bar  |
| Ambient temperature min./max. | -25 ... 80 °C   |
| Medium                        | Compressed air  |
| Weight                        | 0.005 kg  |
| Comment                       | Flow characteristic curves can be found under "Diagrams". |

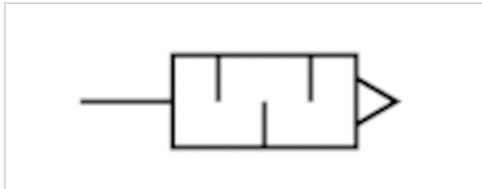

## Technical data

| Part No.   | Compressed air connection | Delivery unit |
|------------|---------------------------|---------------|
| 8140000700 | M7                        | 10 piece      |

Weight per piece

Nominal flow Qn at p1 = 6 bar (absolute) freely discharged. Sound pressure level measured at 6 bar against atmosphere at 1 m distance.

## Technical information

| Material |                 |
|----------|-----------------|
| Silencer | Sintered bronze |
| Thread   | Brass           |

## Dimensions

### Dimensions in mm

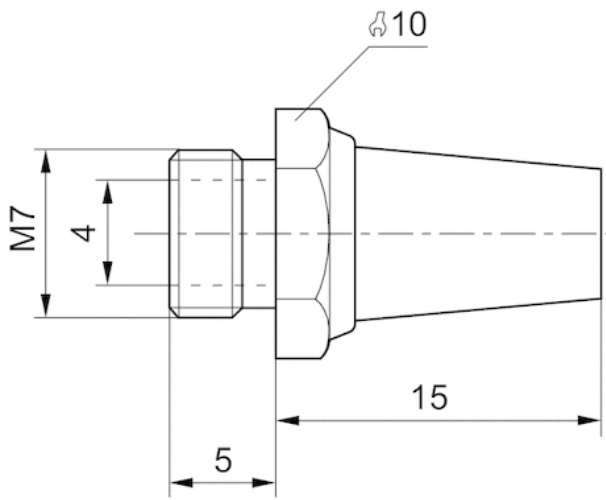

# Silencers, series SI1

- M10x1
- Sintered bronze



|                               |   |
|-------------------------------|---|
| Working pressure min./max.    | 0 ... 10 bar  |
| Ambient temperature min./max. | -25 ... 80 °C   |
| Medium                        | Compressed air  |
| Sound pressure level          | 75 dB   |
| Weight                        | 0.011 kg  |
| Comment                       | Flow characteristic curves can be found under "Diagrams". |

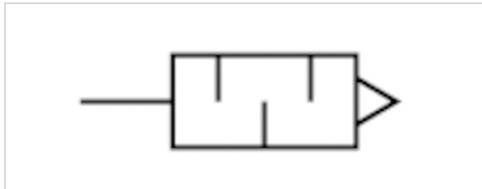

## Technical data

| Part No.   | Compressed air connection | Flow       | Delivery unit |
|------------|---------------------------|------------|---------------|
|            |                           | Qn         |               |
| 5324001110 | M10x1                     | 1747 l/min | 1 piece       |

Weight per piece

Nominal flow Qn at p1 = 6 bar (absolute) freely discharged. Sound pressure level measured at 6 bar against atmosphere at 1 m distance.

## Technical information

| Material |                 |
|----------|-----------------|
| Silencer | Sintered bronze |
| Thread   | Brass           |

## Dimensions

### Dimensions in mm

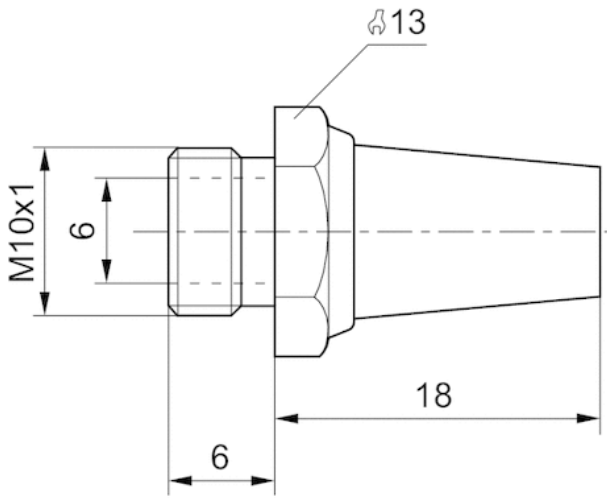

## Diagrams

### Flow diagram, 5324001110

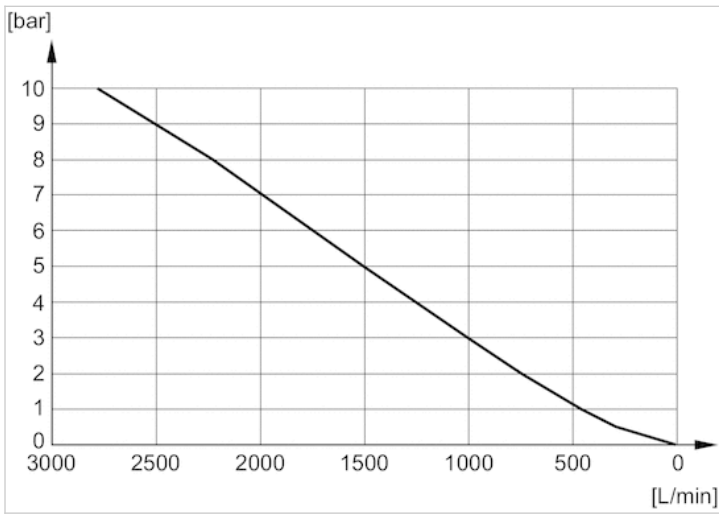

# Silencers, series SI1

- M12x1,5
- Sintered bronze



|                               |   |
|-------------------------------|---|
| Working pressure min./max.    | 0 ... 10 bar  |
| Ambient temperature min./max. | -25 ... 80 °C   |
| Medium                        | Compressed air  |
| Sound pressure level          | 80 dB   |
| Weight                        | 0.019 kg  |
| Comment                       | Flow characteristic curves can be found under "Diagrams". |

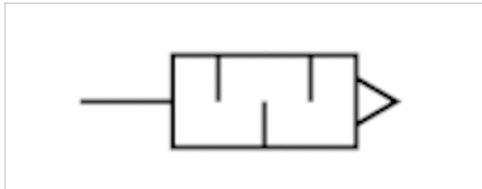

## Technical data

| Part No.   | Compressed air connection | Flow       | Delivery unit |
|------------|---------------------------|------------|---------------|
|            |                           | Qn         |               |
| 5324001170 | M12x1,5                   | 3049 l/min | 1 piece       |

Weight per piece

Nominal flow Qn at p1 = 6 bar (absolute) freely discharged. Sound pressure level measured at 6 bar against atmosphere at 1 m distance.

## Technical information

| Material |                 |
|----------|-----------------|
| Silencer | Sintered bronze |
| Thread   | Brass           |

## Dimensions

### Dimensions in mm

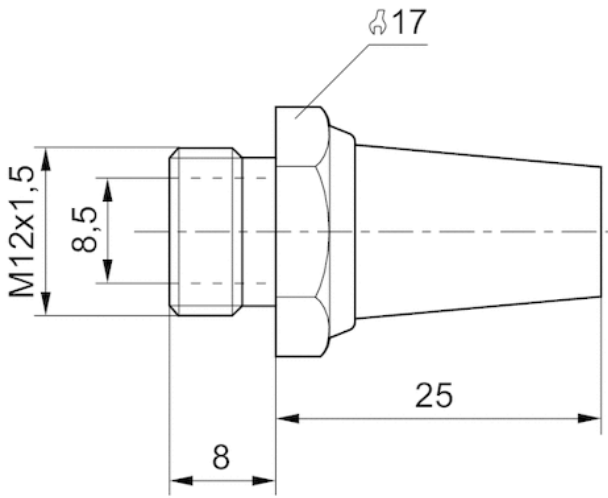

## Diagrams

### Flow diagram, 5324001170

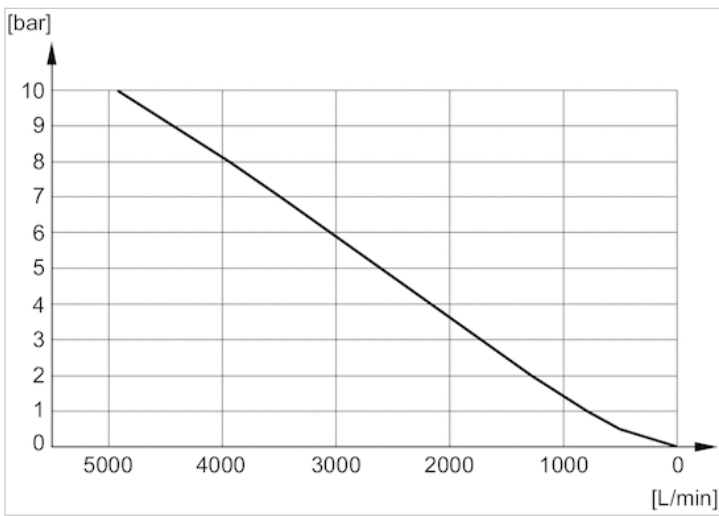



# Silencers, series SI1

- M14x1,5
- Sintered bronze



|                               |   |
|-------------------------------|---|
| Working pressure min./max.    | 0 ... 10 bar  |
| Ambient temperature min./max. | -25 ... 80 °C   |
| Medium                        | Compressed air  |
| Sound pressure level          | 80 dB   |
| Weight                        | 0.018 kg  |
| Comment                       | Flow characteristic curves can be found under "Diagrams". |

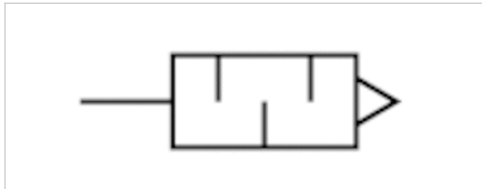

## Technical data

| Part No.   | Compressed air connection | Flow       | Delivery unit |
|------------|---------------------------|------------|---------------|
|            |                           | Qn         |               |
| 5324001120 | M14x1,5                   | 3390 l/min | 1 piece       |

Weight per piece

Nominal flow Qn at p1 = 6 bar (absolute) freely discharged. Sound pressure level measured at 6 bar against atmosphere at 1 m distance.

## Technical information

| Material |                 |
|----------|-----------------|
| Silencer | Sintered bronze |
| Thread   | Brass           |

## Dimensions

### Dimensions in mm

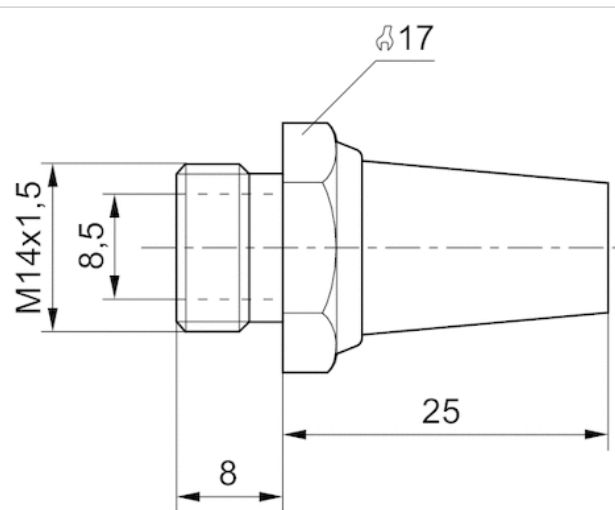

## Diagrams

### Flow diagram, 5324001120

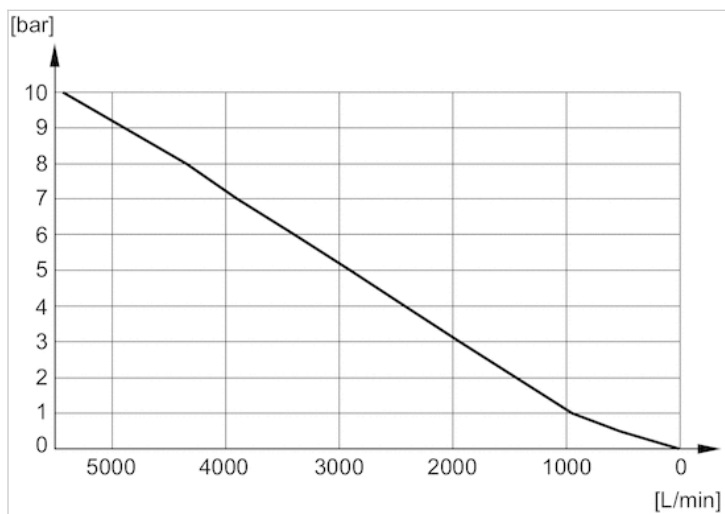

# Silencers, series SI1

- M22x1,5
- Sintered bronze



|                               |   |
|-------------------------------|---|
| Working pressure min./max.    | 0 ... 10 bar  |
| Ambient temperature min./max. | -25 ... 80 °C   |
| Medium                        | Compressed air  |
| Sound pressure level          | 85 dB   |
| Weight                        | 0.071 kg  |
| Comment                       | Flow characteristic curves can be found under "Diagrams". |

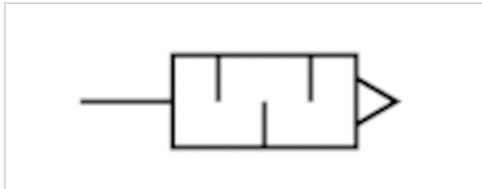

## Technical data

| Part No.   | Compressed air connection | Flow       | Delivery unit |
|------------|---------------------------|------------|---------------|
|            |                           | Qn         |               |
| 5324001140 | M22x1,5                   | 7223 l/min | 1 piece       |

Weight per piece

Nominal flow Qn at p1 = 6 bar (absolute) freely discharged. Sound pressure level measured at 6 bar against atmosphere at 1 m distance.

## Technical information

| Material |                 |
|----------|-----------------|
| Silencer | Sintered bronze |
| Thread   | Brass           |

## Dimensions

### Dimensions in mm

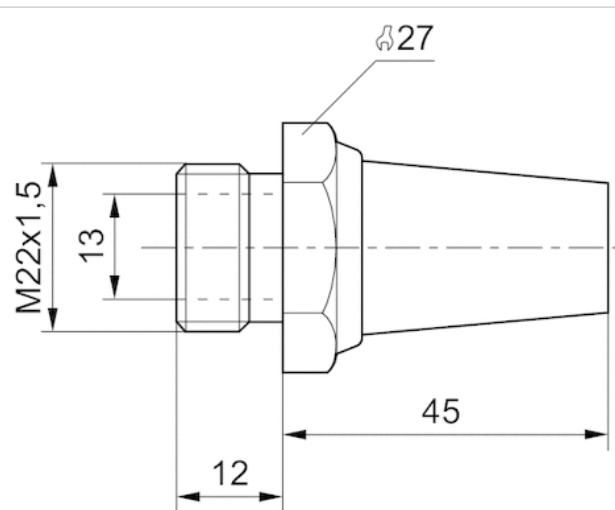

## Diagrams

### Flow diagram, 5324001140

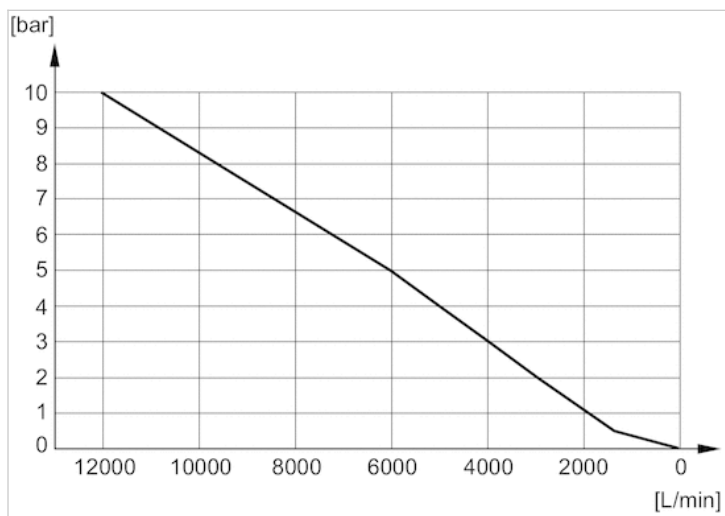

# Silencers, series SI1

- G 1/8
- Sintered bronze



|                               |   |
|-------------------------------|---|
| Working pressure min./max.    | 0 ... 10 bar  |
| Ambient temperature min./max. | -25 ... 80 °C   |
| Medium                        | Compressed air  |
| Sound pressure level          | 75 dB   |
| Weight                        | 0.01 kg   |
| Comment                       | Flow characteristic curves can be found under "Diagrams". |

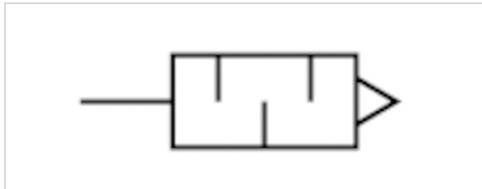

## Technical data

| Part No.   | Compressed air connection | Flow       | Delivery unit |
|------------|---------------------------|------------|---------------|
|            |                           | Qn         |               |
| 1827000000 | G 1/8                     | 1623 l/min | 10 piece      |

Weight per piece

Nominal flow Qn at p1 = 6 bar (absolute) freely discharged. Sound pressure level measured at 6 bar against atmosphere at 1 m distance.

## Technical information

| Material |                 |
|----------|-----------------|
| Silencer | Sintered bronze |
| Thread   | Brass           |

## Dimensions

### Dimensions in mm

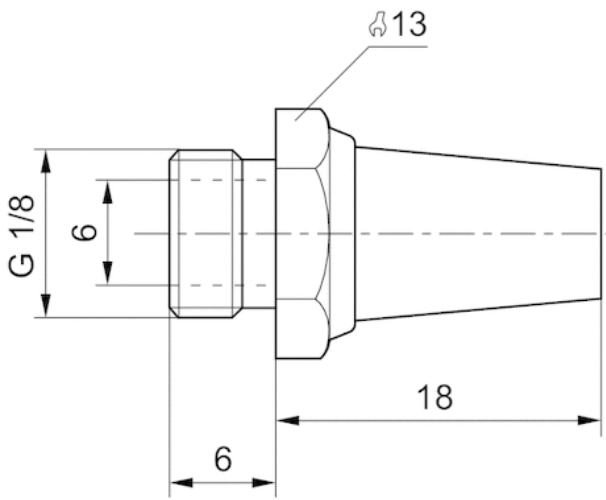

## Diagrams

### Flow diagram, 1827000000

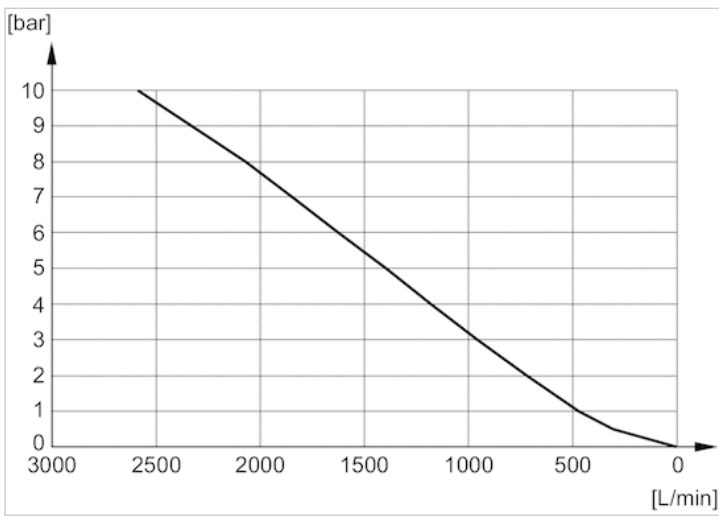

# Silencers, series SI1

- G 1/4
- Sintered bronze



|                               |   |
|-------------------------------|---|
| Working pressure min./max.    | 0 ... 10 bar  |
| Ambient temperature min./max. | -25 ... 80 °C   |
| Medium                        | Compressed air  |
| Sound pressure level          | See table below   |
| Weight                        | See table below   |
| Comment                       | Flow characteristic curves can be found under "Diagrams". |

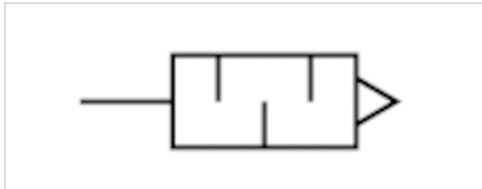

## Technical data

| Part No.   | Compressed air connection | Sound pressure level | Flow       | Delivery unit | Weight   |
|------------|---------------------------|----------------------|------------|---------------|----------|
|            |                           |                      | Qn         |               |          |
| R412004817 | G 1/4                     | -                    | 5950 l/min | 10 piece      | 0.013 kg |
| 1827000001 | G 1/4                     | 79 dB                | 3390 l/min | 10 piece      | 0.02 kg  |

Weight per piece

Nominal flow Qn at p1 = 6 bar (absolute) freely discharged. Sound pressure level measured at 6 bar against atmosphere at 1 m distance.

## Technical information

| Material |                 |
|----------|-----------------|
| Silencer | Sintered bronze |
| Thread   | Brass           |

## Dimensions

### Dimensions in mm

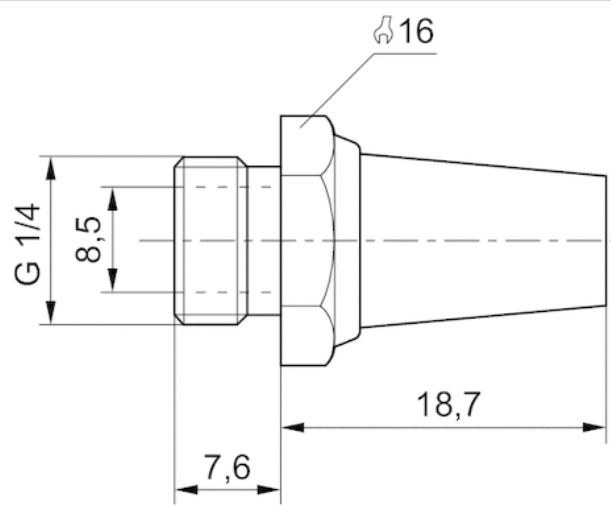

### Dimensions in mm

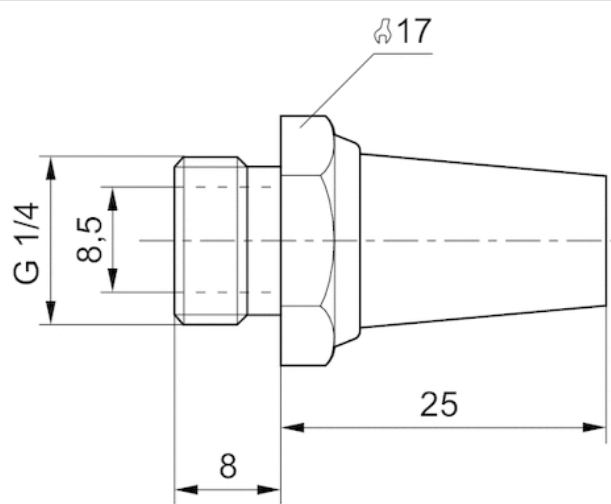



# Silencers, series SI1

- G 3/8
- Sintered bronze



|                               |   |
|-------------------------------|---|
| Working pressure min./max.    | 0 ... 10 bar  |
| Ambient temperature min./max. | -25 ... 80 °C   |
| Medium                        | Compressed air  |
| Sound pressure level          | 84 dB   |
| Weight                        | 0.05 kg   |
| Comment                       | Flow characteristic curves can be found under "Diagrams". |

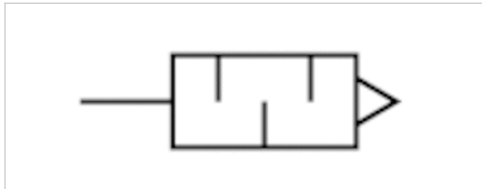

## Technical data

| Part No.   | Compressed air connection | Flow       | Delivery unit |
|------------|---------------------------|------------|---------------|
|            |                           | Qn         |               |
| 1827000002 | G 3/8                     | 6554 l/min | 5 piece       |

Weight per piece

Nominal flow Qn at p1 = 6 bar (absolute) freely discharged. Sound pressure level measured at 6 bar against atmosphere at 1 m distance.

## Technical information

| Material |                 |
|----------|-----------------|
| Silencer | Sintered bronze |
| Thread   | Brass           |

## Dimensions

### Dimensions in mm

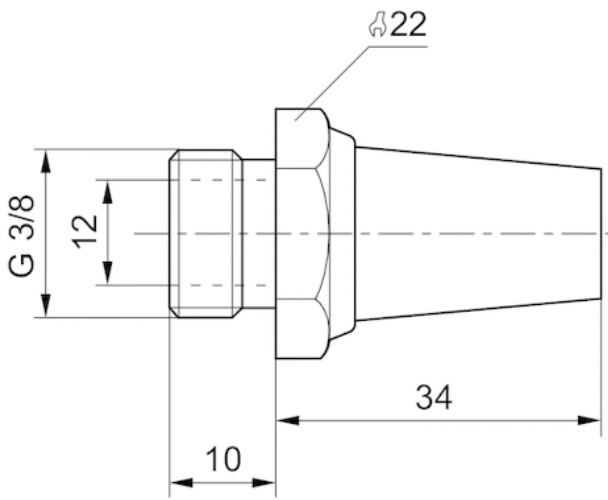

## Diagrams

### Flow diagram, 1827000002

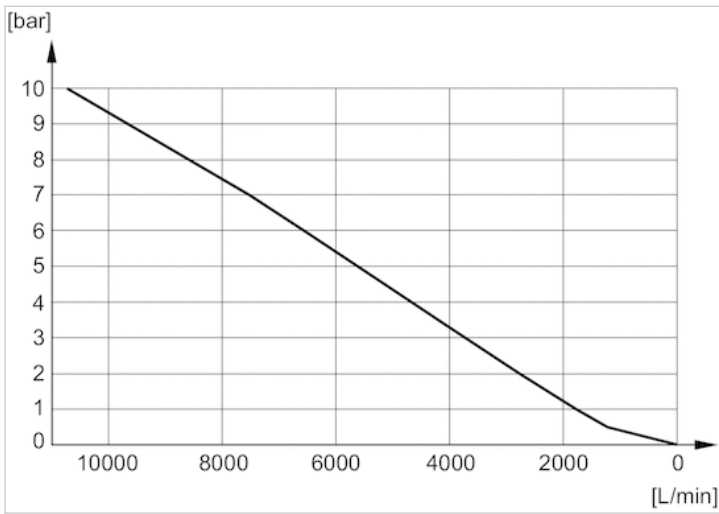

# Silencers, series SI1

- G 1/2
- Sintered bronze



|                               |   |
|-------------------------------|---|
| Working pressure min./max.    | 0 ... 10 bar  |
| Ambient temperature min./max. | -25 ... 80 °C   |
| Medium                        | Compressed air  |
| Sound pressure level          | 90 dB   |
| Weight                        | 0.08 kg   |
| Comment                       | Flow characteristic curves can be found under "Diagrams". |

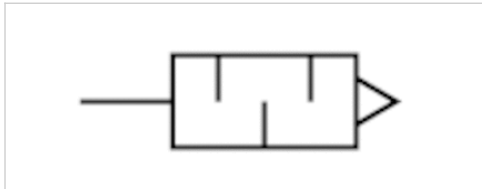

## Technical data

| Part No.   | Compressed air connection | Flow       | Delivery unit |
|------------|---------------------------|------------|---------------|
|            |                           | Qn         |               |
| 1827000003 | G 1/2                     | 7223 l/min | 2 piece       |

Weight per piece

Nominal flow Qn at p1 = 6 bar (absolute) freely discharged. Sound pressure level measured at 6 bar against atmosphere at 1 m distance.

## Technical information

| Material |                 |
|----------|-----------------|
| Silencer | Sintered bronze |
| Thread   | Brass           |

## Dimensions

### Dimensions in mm

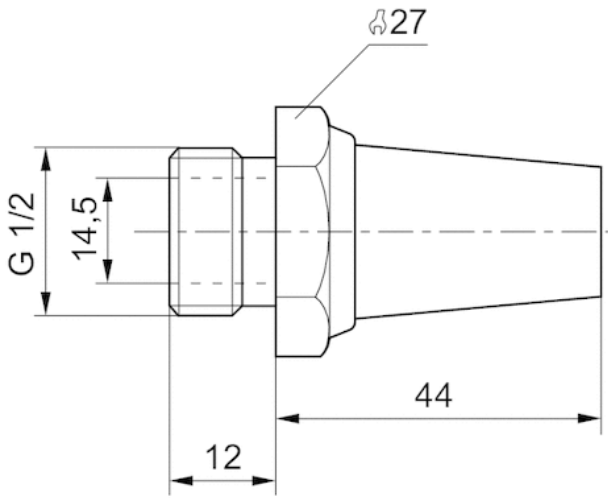

## Diagrams

### Flow diagram, 1827000003

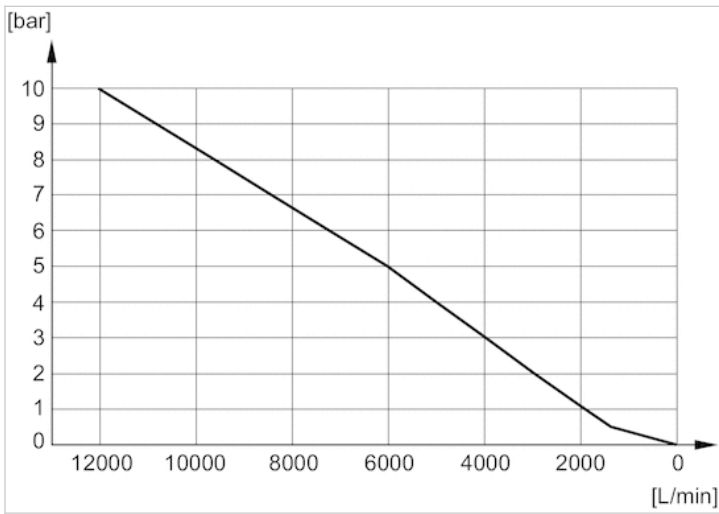

# Silencers, series SI1

- G 3/4
- Sintered bronze



|                               |   |
|-------------------------------|---|
| Working pressure min./max.    | 0 ... 10 bar  |
| Ambient temperature min./max. | -25 ... 80 °C   |
| Medium                        | Compressed air  |
| Sound pressure level          | 92 dB   |
| Weight                        | 0.13 kg   |
| Comment                       | Flow characteristic curves can be found under "Diagrams". |

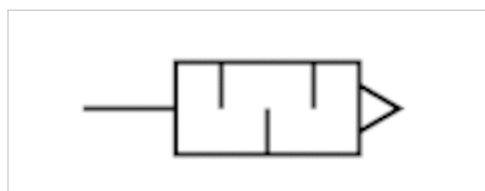

## Technical data

| Part No.   | Compressed air connection | Flow       | Delivery unit |
|------------|---------------------------|------------|---------------|
|            |                           | Qn         |               |
| 1827000004 | G 3/4                     | 8394 l/min | 1 piece       |

Weight per piece

Nominal flow Qn at p1 = 6 bar (absolute) freely discharged. Sound pressure level measured at 6 bar against atmosphere at 1 m distance.

## Technical information

| Material |                 |
|----------|-----------------|
| Silencer | Sintered bronze |
| Thread   | Brass           |

## Dimensions

### Dimensions in mm

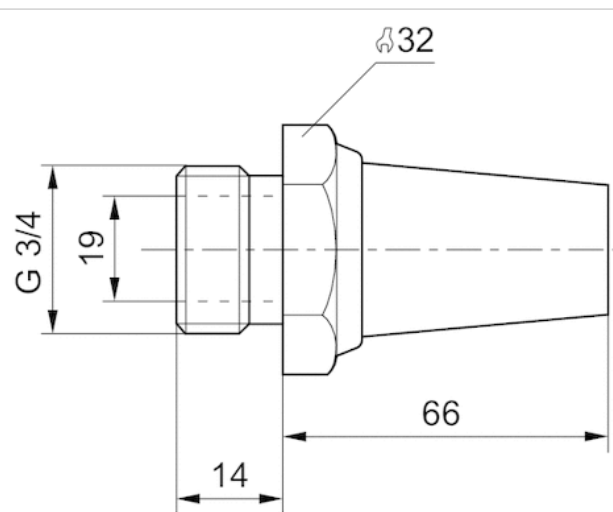

## Diagrams

### Flow diagram, 1827000004

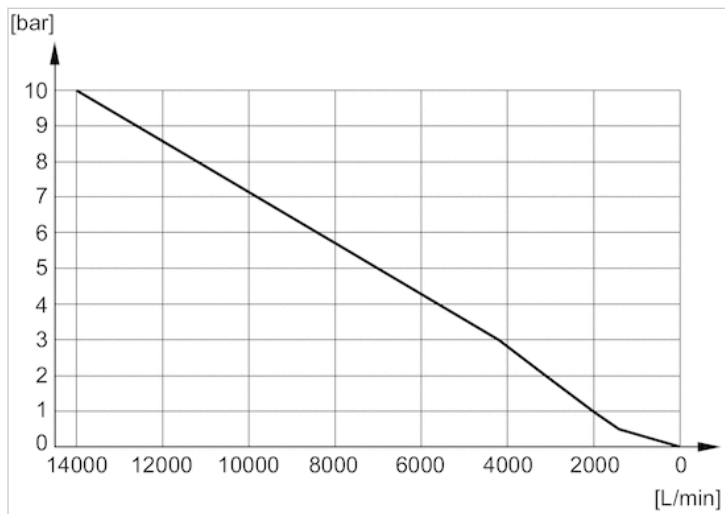

# Silencers, series SI1

- G 1

- Sintered bronze



Working pressure min./max.

0 ... 10 bar

Ambient temperature min./max.

-25 ... 80 °C

Medium

Compressed air

Sound pressure level

102 dB

Weight

0.18 kg

Comment

Flow characteristic curves can be found under "Diagrams".

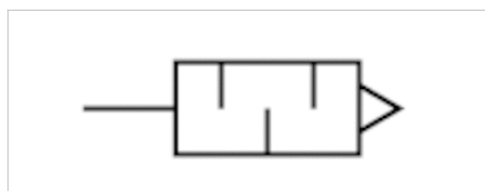

## Technical data

| Part No.   | Compressed air connection | Flow        | Delivery unit |
|------------|---------------------------|-------------|---------------|
|            |                           | Qn          |               |
| 1827000005 | G 1                       | 12848 l/min | 1 piece       |

Weight per piece

Nominal flow Qn at p1 = 6 bar (absolute) freely discharged. Sound pressure level measured at 6 bar against atmosphere at 1 m distance.

## Technical information

| Material |                 |
|----------|-----------------|
| Silencer | Sintered bronze |
| Thread   | Brass           |

## Dimensions

### Dimensions in mm

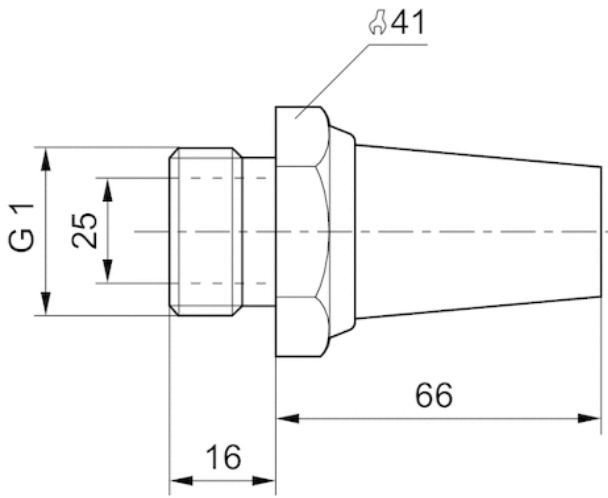

## Diagrams

### Flow diagram, 1827000005

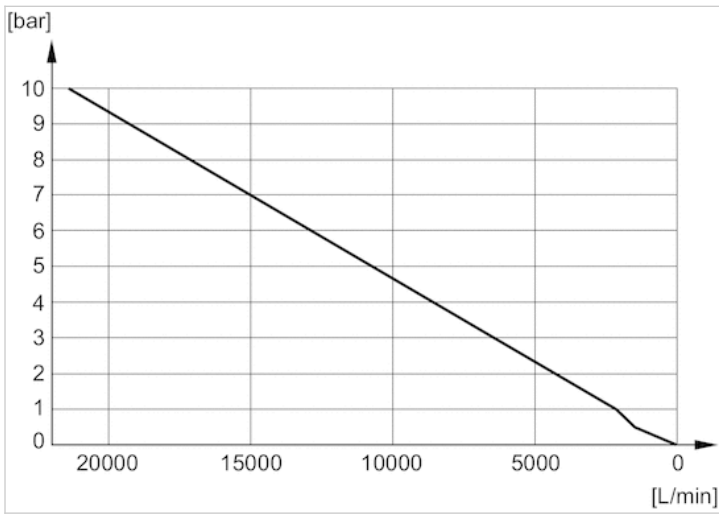



# Silencers, series SI1

- M5 G 1/8 G 1/4 G 3/8 G 1/2 G 3/4 G 1

- Sintered bronze

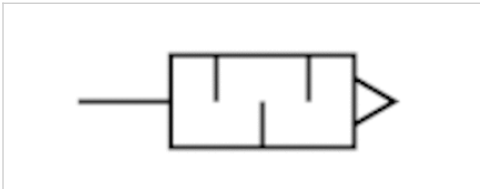

Working pressure min./max.

0 ... 10 bar

Ambient temperature min./max.

-25 ... 80 °C

Medium

Compressed air

Sound pressure level

See table below

Weight

See table below

Comment

Flow characteristic curves can be found under "Diagrams".

## Technical data

| Part No.   | Compressed air connection | Sound pressure level | Flow       | Delivery unit | Weight   |
|------------|---------------------------|----------------------|------------|---------------|----------|
|            |                           |                      | Qn         |               |          |
| 1827000032 | M5                        | 79 dB                | 252 l/min  | 10 piece      | 0.005 kg |
| 1827000031 | G 1/8                     | 85 dB                | 700 l/min  | 10 piece      | 0.001 kg |
| 1827000033 | G 1/4                     | 88 dB                | 1116 l/min | 10 piece      | 0.01 kg  |
| 1827000034 | G 3/8                     | 90 dB                | 1706 l/min | 5 piece       | 0.016 kg |
| 1827000035 | G 1/2                     | 85 dB                | 2568 l/min | 2 piece       | 0.035 kg |
| 8145003400 | G 3/4                     | 82 dB                | 3260 l/min | 1 piece       | 0.095 kg |
| 8145001000 | G 1                       | 82 dB                | 9485 l/min | 1 piece       | 0.057 kg |

Weight per piece

Nominal flow Qn at p1 = 6 bar (absolute) freely discharged. Sound pressure level measured at 6 bar against atmosphere at 1 m distance.

## Technical information

| Material |                 |
|----------|-----------------|
| Silencer | Sintered bronze |
| Thread   | Brass           |

## Dimensions

### Dimensions

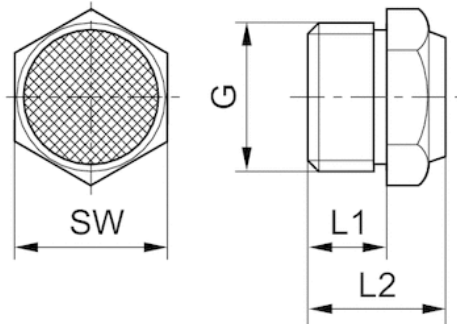

## Dimensions

| Part No.   | Port G | L1 | L2   | SW |
|------------|--------|----|------|----|
| 1827000032 | M5     | 5  | 10.3 | 7  |
| 1827000031 | G 1/8  | 6  | 11.5 | 13 |
| 1827000033 | G 1/4  | 8  | 13.5 | 17 |
| 1827000034 | G 3/8  | 10 | 17.5 | 22 |
| 1827000035 | G 1/2  | 12 | 19.5 | 27 |
| 8145003400 | G 3/4  | 14 | 22.5 | 32 |
| 8145001000 | G 1    | 16 | 22.5 | 41 |

Sound pressure level measured at 6 bar at 1 m distance

## Diagrams

### Flow diagram, 1827000032

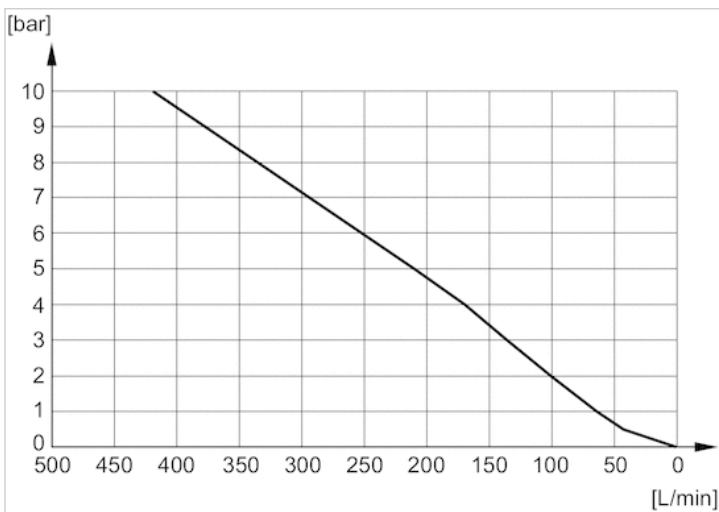

Flow diagram, 1827000031

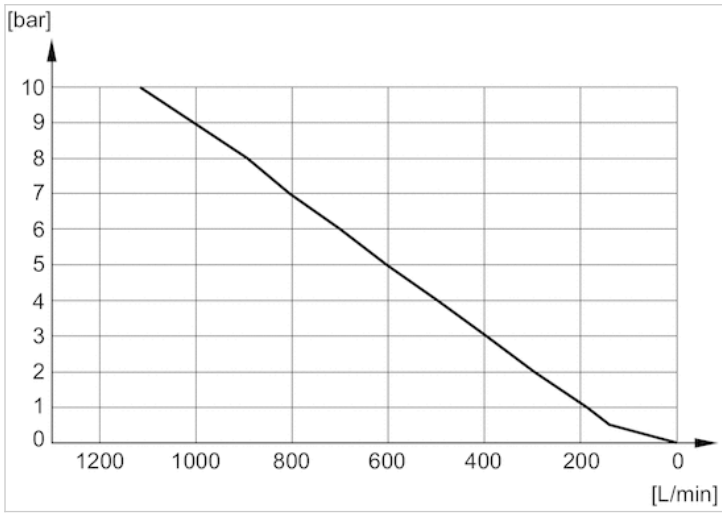

Flow diagram, 1827000033

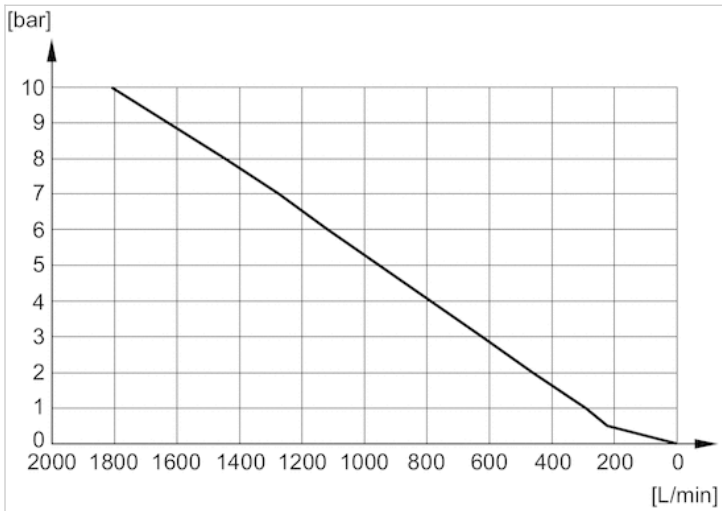

Flow diagram, 1827000034

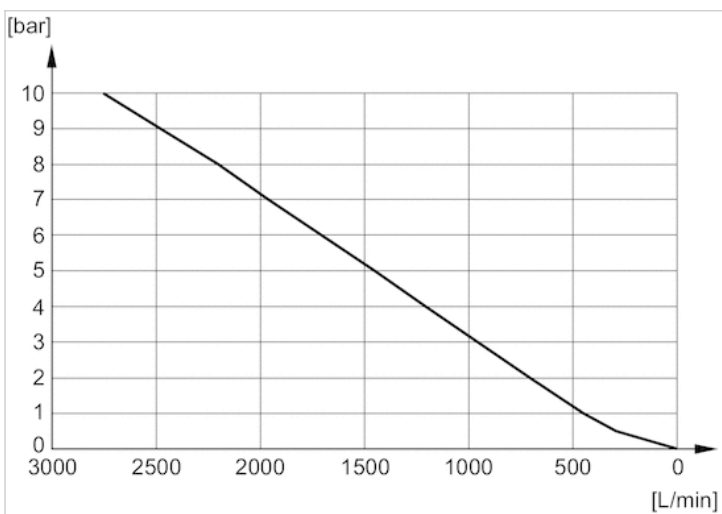

Flow diagram, 1827000035

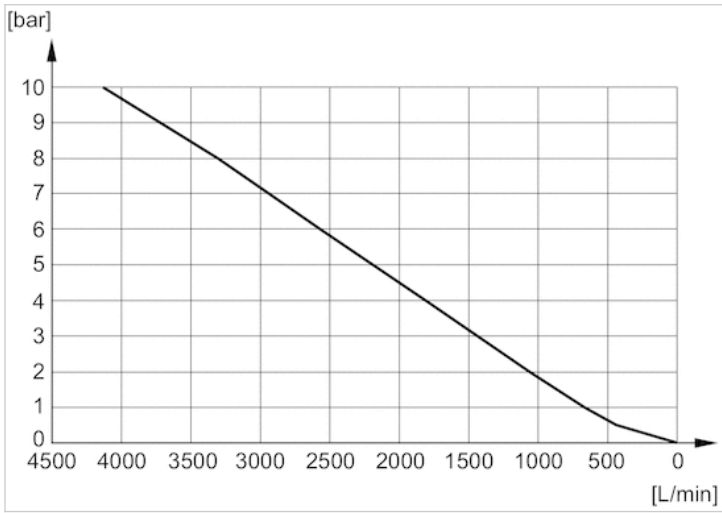

Flow diagram, 8145003400

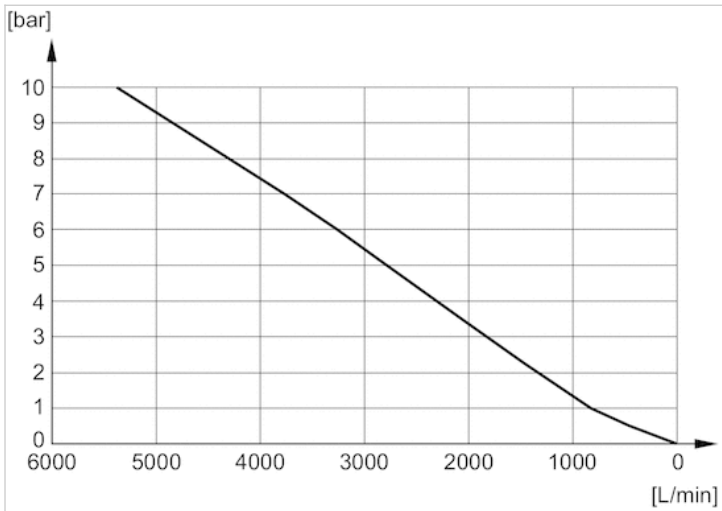

Flow diagram, 8145001000

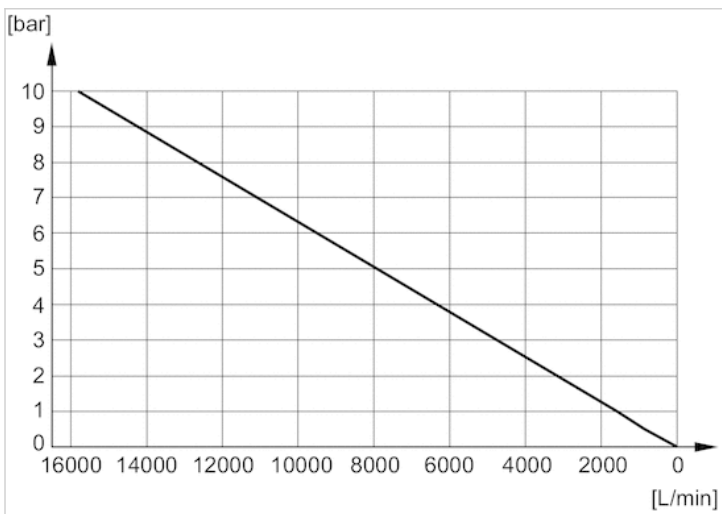

# Silencers, series SI1

- G 1/8 G 1/4 G 3/8 G 1/2 G 3/4 G 1

- Sintered bronze



Working pressure min./max.

0 ... 10 bar

Ambient temperature min./max.

-25 ... 80 °C

Medium

Compressed air

Comment

Flow characteristic curves can be found under "Diagrams".

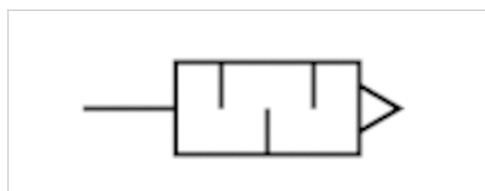

## Technical data

| Part No.   | Compressed air connection | Flow       | Delivery unit |
|------------|---------------------------|------------|---------------|
|            |                           | Qn         |               |
| 1827430004 | G 1/8                     | 311 l/min  | 10 piece      |
| R414000155 | G 1/4                     | 553 l/min  | 10 piece      |
| R412007875 | G 3/8                     | 743 l/min  | 5 piece       |
| R412007876 | G 1/2                     | 1343 l/min | 2 piece       |
| R412007877 | G 3/4                     | 3585 l/min | 2 piece       |
| R412007878 | G 1                       | 5012 l/min | 2 piece       |

Nominal flow Qn at p1 = 6 bar (absolute) freely discharged. Sound pressure level measured at 6 bar against atmosphere at 1 m distance.

## Technical information

| Material |                 |
|----------|-----------------|
| Silencer | Sintered bronze |
| Thread   | Brass           |

## Dimensions

### Dimensions

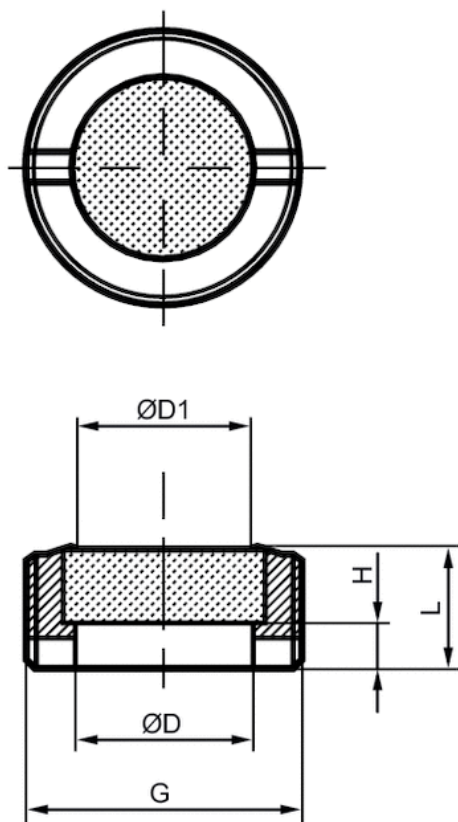

## Dimensions

| Part No.   | Port G | $\varnothing D$ | $\varnothing D1$ | H   | L   |
|------------|--------|-----------------|------------------|-----|-----|
| 1827430004 | G 1/8  | 6               | 5                | 2   | 4   |
| R414000155 | G 1/4  | 8               | 6                | 3   | 6   |
| R412007875 | G 3/8  | 10              | 8                | 3   | 7   |
| R412007876 | G 1/2  | 15              | 12               | 5   | 9   |
| R412007877 | G 3/4  | 20              | 17               | 3.4 | 8   |
| R412007878 | G 1    | 26              | 23               | 5.5 | 9.5 |

## Diagrams

Flow diagram, 1827430004

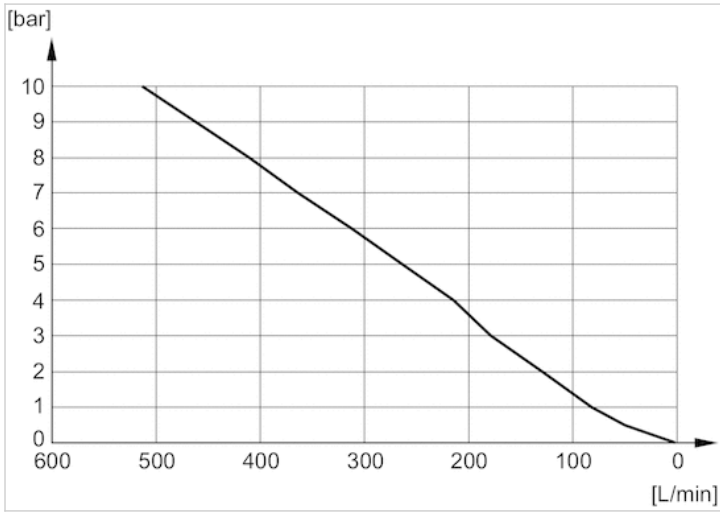

Flow diagram, R414000155

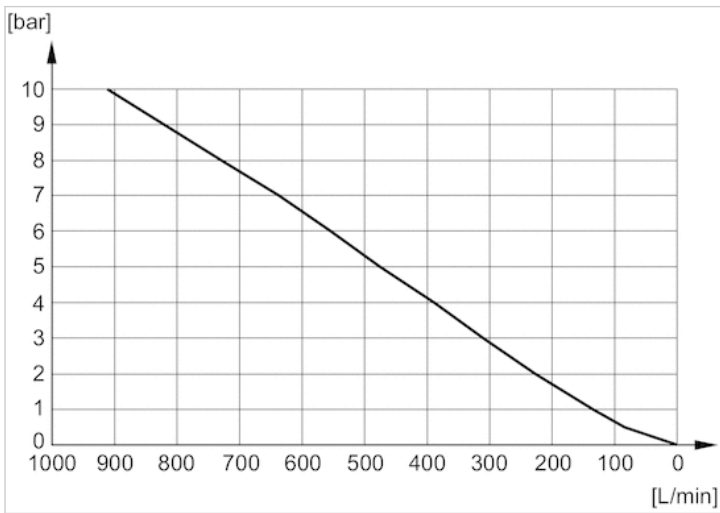

R412007875

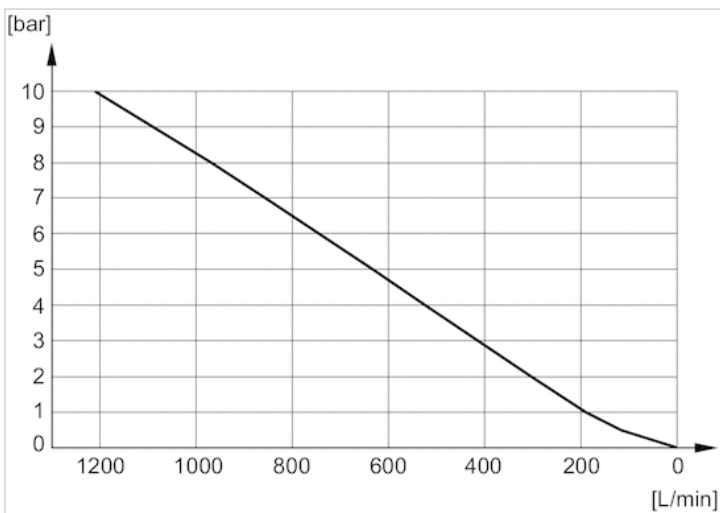

Flow diagram, R412007876

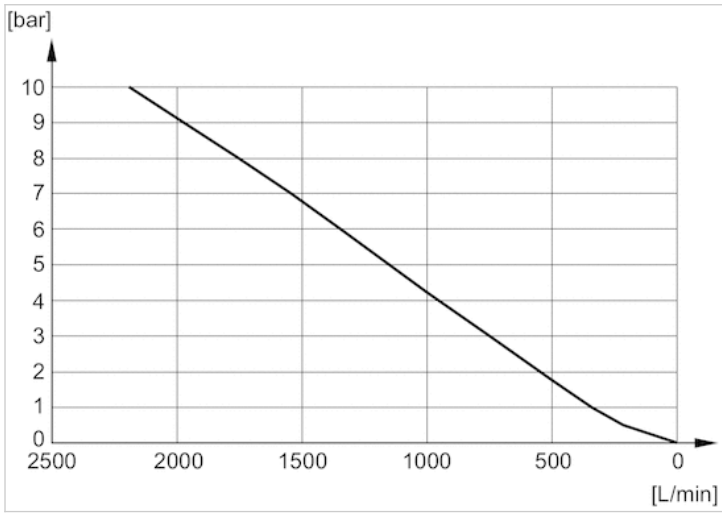

Flow diagram, R412007877

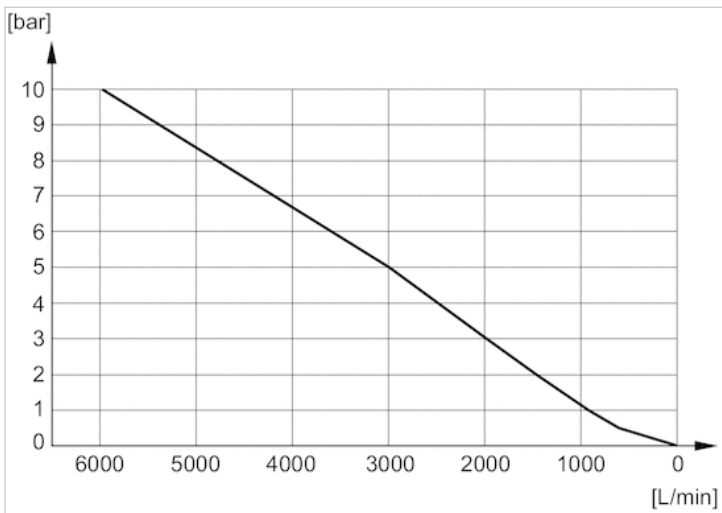

Flow diagram, R412007878

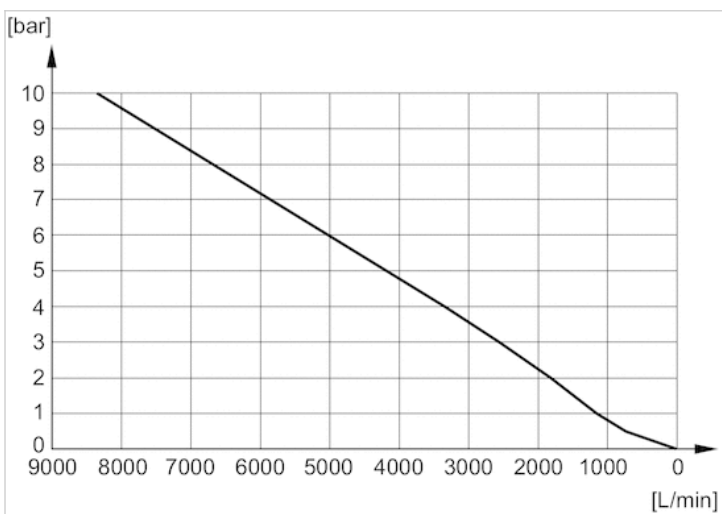



# Silencers, series SI1

- M5 G 1/8 G 1/4 G 3/8 G 1/2 G 3/4 G 1

- Polyethylene



|                               |                 |
|-------------------------------|-----------------|
| Working pressure min./max.    | 0 ... 10 bar    |
| Ambient temperature min./max. | -25 ... 80 °C   |
| Medium                        | Compressed air  |
| Sound pressure level          | See table below |
| Weight                        | See table below |

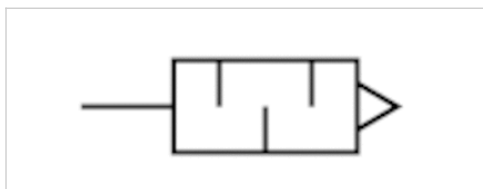

## Technical data

| Part No.   | Compressed air connection | Sound pressure level | Flow        | Delivery unit | Weight   |
|------------|---------------------------|----------------------|-------------|---------------|----------|
|            |                           |                      | Qn          |               |          |
| 1827000018 | M5                        | -                    | 381 l/min   | 5 piece       | 0.001 kg |
| 1827000019 | G 1/8                     | 78 dB                | 1560 l/min  | 5 piece       | 0.002 kg |
| 1827000020 | G 1/4                     | 80 dB                | 3447 l/min  | 5 piece       | 0.003 kg |
| 1827000021 | G 3/8                     | 85 dB                | 5682 l/min  | 2 piece       | 0.008 kg |
| 1827000022 | G 1/2                     | 88 dB                | 7142 l/min  | 1 piece       | 0.013 kg |
| 1827000023 | G 3/4                     | -                    | 8356 l/min  | 1 piece       | 0.04 kg  |
| 1827000024 | G 1                       | -                    | 13329 l/min | 1 piece       | 0.055 kg |

Weight per piece

Nominal flow Qn at p1 = 6 bar (absolute) freely discharged. Sound pressure level measured at 6 bar against atmosphere at 1 m distance.

## Technical information

Flow characteristic curves can be found under "Diagrams".

## Technical information

| Material |              |
|----------|--------------|
| Silencer | Polyethylene |
| Thread   | Polyethylene |

## Dimensions

### Dimensions

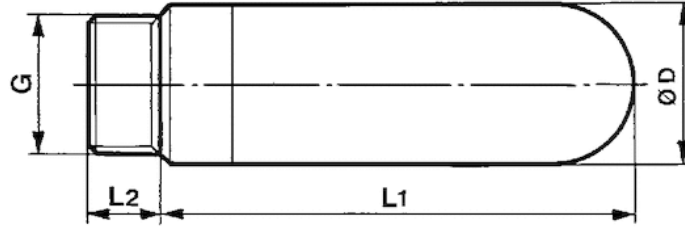

## Dimensions

| Part No.   | Port G | Ø D  | L1    | L2   |
|------------|--------|------|-------|------|
| 1827000018 | M5     | 6.5  | 17.5  | 4    |
| 1827000019 | G 1/8  | 12.5 | 28.5  | 5.5  |
| 1827000020 | G 1/4  | 15.5 | 34.5  | 8    |
| 1827000021 | G 3/8  | 18.5 | 56    | 11.5 |
| 1827000022 | G 1/2  | 23.3 | 66.5  | 11   |
| 1827000023 | G 3/4  | 38.5 | 115.5 | 16   |
| 1827000024 | G 1    | 49   | 140   | 21   |

## Diagrams

### Flow diagram, 1827000018

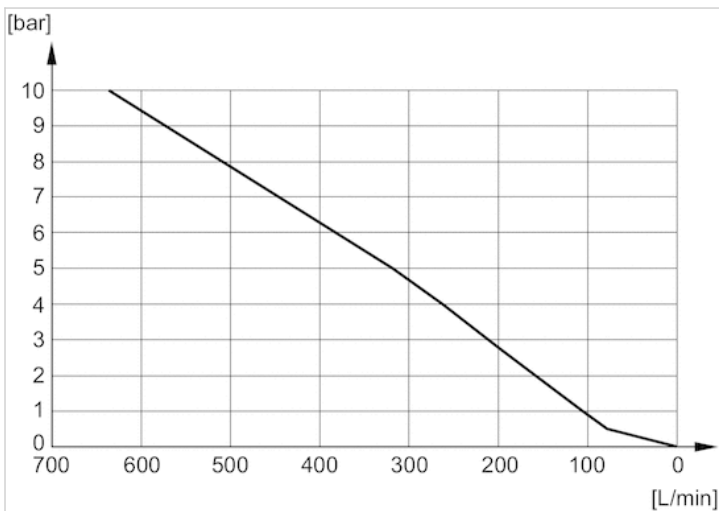

Flow diagram, 1827000019

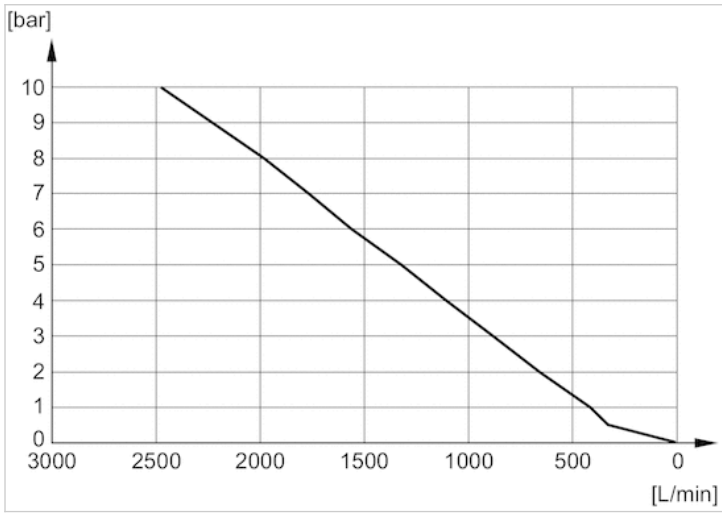

Flow diagram, 1827000020

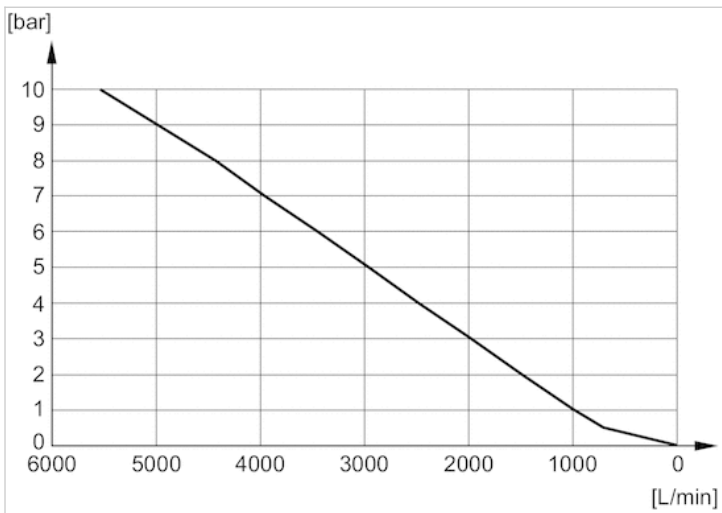

Flow diagram, 1827000021

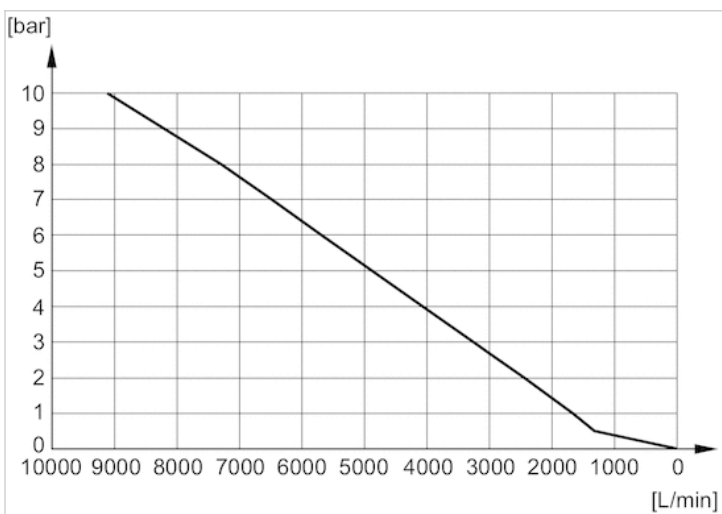

Flow diagram, 1827000022

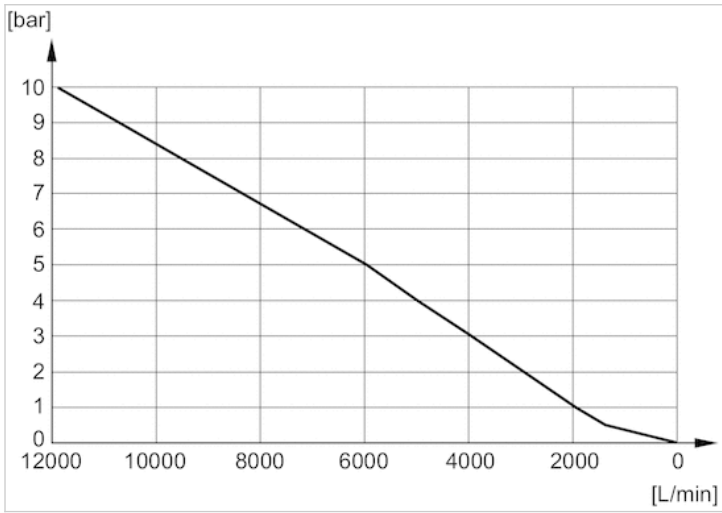

Flow diagram, 1827000023

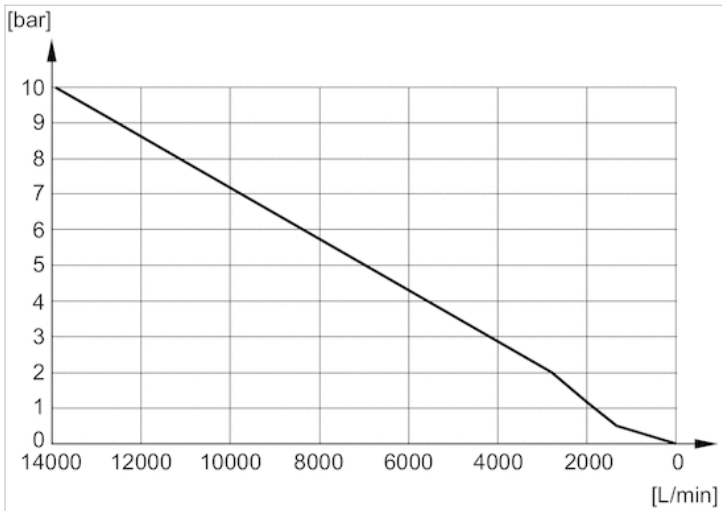

Flow diagram, 1827000024

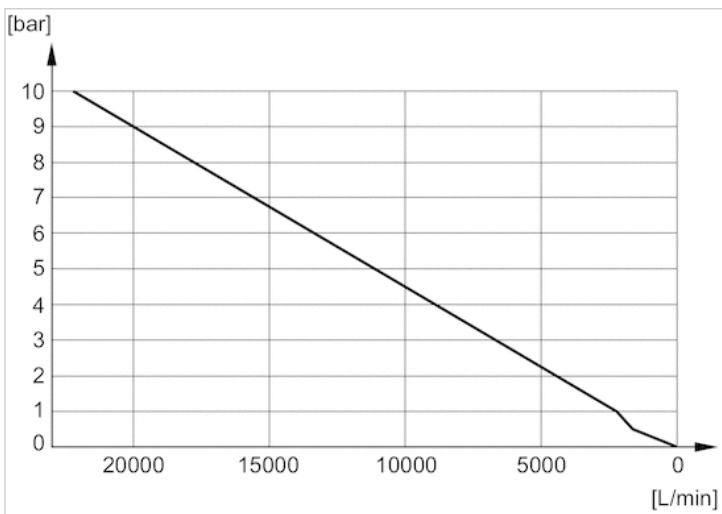

# Efficient pneumatic solutions, our program: cylinders and drives, valves and valve systems, air supply management



Visit us: [Emerson.com/Aventics](https://www.emerson.com/Aventics)

Your local contact: [Emerson.com/contactus](https://www.emerson.com/contactus)



Emerson.com



[Facebook.com/EmersonAutomationSolutions](https://www.facebook.com/EmersonAutomationSolutions)



[LinkedIn.com/company/Emerson-Automation-Solutions](https://www.linkedin.com/company/Emerson-Automation-Solutions)



[Twitter.com/EMR\\_Automation](https://twitter.com/EMR_Automation)

An example configuration is depicted on the title page. The delivered product may thus vary from that in the illustration. Subject to change. This Document, as well as the data, specifications and other information set forth in it, are the exclusive property of AVENTICS GmbH. It may not be reproduced or given to third parties without its consent. Only use the AVENTICS products shown in industrial applications. Read the product documentation completely and carefully before using the product. Observe the applicable regulations and laws of the respective country. When integrating the product into applications, note the system manufacturer's specifications for safe use of the product. The data specified only serve to describe the product. No statements concerning a certain condition or suitability for a certain application can be derived from our information. The information given does not release the user from the obligation of own judgment and verification. It must be remembered that the products are subject to a natural process of wear and aging.

The Emerson logo is a trademark and service mark of Emerson Electric Co. Brand logotype are registered trademarks of one of the Emerson family of companies. All other marks are the property of their respective owners. © 2017 Emerson Electric Co. All rights reserved.  
2019-03



**CONSIDER IT SOLVED™**